

# VW Surface-Mount Strain Gauge

52650399

Copyright ©2003 Slope Indicator Company. All Rights Reserved.

This equipment should be installed, maintained, and operated by technically qualified personnel. Any errors or omissions in data, or the interpretation of data, are not the responsibility of Slope Indicator Company. The information herein is subject to change without notification.

This document contains information that is proprietary to Slope Indicator company and is subject to return upon request. It is transmitted for the sole purpose of aiding the transaction of business between Slope Indicator Company and the recipient. All information, data, designs, and drawings contained herein are proprietary to and the property of Slope Indicator Company, and may not be reproduced or copied in any form, by photocopy or any other means, including disclosure to outside parties, directly or indirectly, without permission in writing from Slope Indicator Company.

## **SLOPE INDICATOR**

12123 Harbour Reach Drive  
Mukilteo, Washington, USA, 98275  
Tel: 425-493-6200 Fax: 425-493-6250  
E-mail: [solutions@slope.com](mailto:solutions@slope.com)  
Website: [www.slopeindicator.com](http://www.slopeindicator.com)

---

# Contents

Introduction .....	1
Installation Notes .....	2
Installation on Steel .....	4
Installation on Concrete & Masonry .	6
Taking Readings .....	8
Data Reduction .....	10

# Introduction

**Applications** Surface-mount strain gauges are used to monitor strain in steel. They can also be used to monitor strain in concrete or masonry structures.

**Operation** The strain gauge operates on the principle that a tensioned wire, when plucked, vibrates at its resonant frequency. The square of this frequency is proportional to the tension in the wire.

The body of the gauge contains a wire that is held in tension between the two end blocks. The end blocks are fixed to the structure via mounting plates. Loading of the structure changes the distance between the two end blocks and results in a change in the tension of the wire.

An electromagnetic coil is attached to the body of the gauge. When activated by a readout, the coil magnetically plucks the wire and then transmits the resulting frequency signal back to the readout.

A change in strain is calculated by finding the difference between the initial reading and a subsequent reading and then multiplying by a gauge factor.

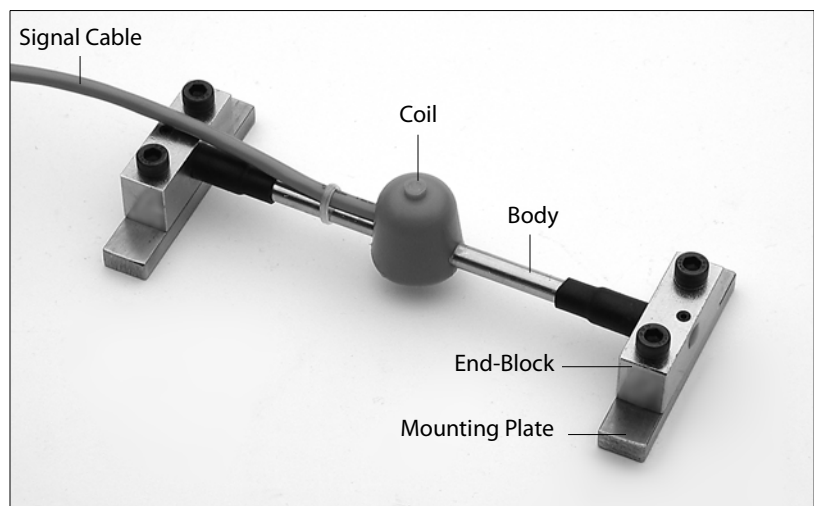

*VW Surface-Mount Strain Gauge on Mounting Plates*

# Installation Notes

## Components

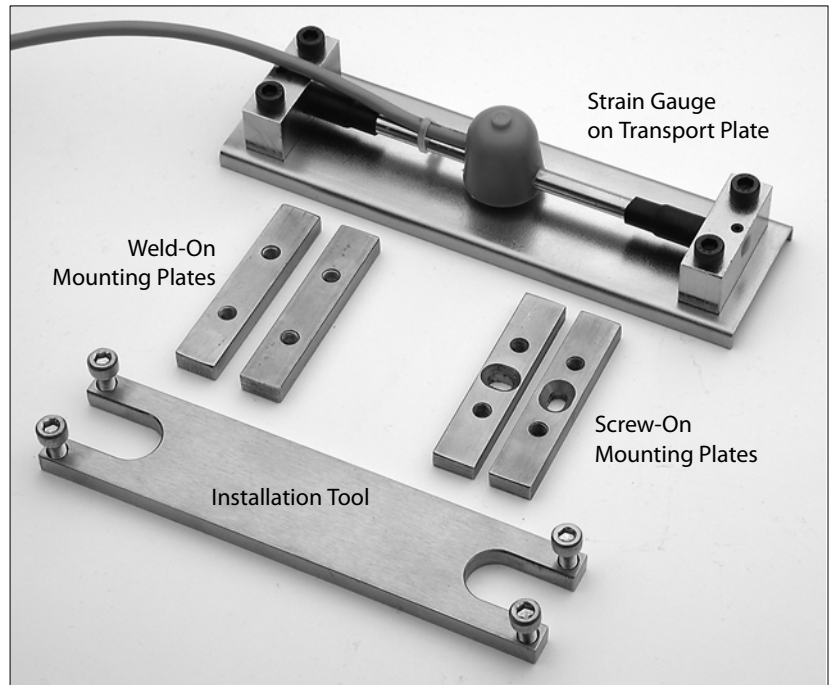

**Strain Gauge:** The strain gauge is supplied on a transport plate. The screws holding the gauge to the transport plate are used to fix the gauge to the mounting plates.

**Mounting Plates:** Weld-on plates are available to mount the strain gauge on steel. Screw-on plates are available to mount the gauge on masonry or concrete using a cement and screws.

**Installation Tool:** The installation tool is used to hold the mounting plates in precise alignment during welding or cementing.

---

## Installation Suggestions

Here are some handling and installation suggestions.

- Sensor**
- Keep strain gauge on its transport plate until you have installed mounting blocks are ready to bolt on the gauge.
  - Do not twist or pull the end blocks of the gauge.
- Signal Cable**
- Mark cables before installation to help you identify the sensor and cable at the end of the installation process. Add extra identification marks at locations where the cable is vulnerable or must be spliced. This precaution may make it possible to reconnect a bundle of broken cables. Also add extra marks toward the end of the cable, where excess cable length may be cut off.
  - Protect cables where they are likely to be damaged.
  - Provide strain relief for signal cables by leaving some slack in the cable run.
- Mounting Considerations**
- Orientation** Position the strain gauge so that its long axis is parallel with the axis of loading.
- Bending:** The strain gauge should be installed along the neutral axis of the structural member when possible. Bending will increase strain on one side of the neutral axis and decrease strain on the opposite side. Axial strain can be isolated from bending strain by installing gauges on opposite sides of the member and averaging the change in strain reported by both gauges.
- Irregularities:** Avoid installing strain gauges near irregularities in the member or near the ends of the member since readings from these locations may not adequately represent strain in the other portions of the member.
- Sunlight:** Consider insulating the gauges from direct sunlight so that they remain the same temperature as the underlying structure.
- Protection:** Consider installing steel protection over the strain gauges to prevent them being damaged.

# Installation on Steel

## Plan the Installation

1. Determine the location and orientation for each gauge.
2. Establish locations for cable runs, conduit, terminal boxes. If any welding is required for this, do it now.

## Prepare the Surface

1. Remove any oil, paint, or other coatings from the weld area.
2. Grind or file any surface irregularities, then clean the entire area with a wire brush. Degrease with a solvent, if necessary.

## Weld the Mounting Plates

1. Confirm the location and orientation for the gauge
2. Screw the installation tool onto the mounting plates.
3. Position the plates in the intended location. Check that the plates sit squarely on the surface. If the plates rock, build up the surface with weld or remove high spots as necessary.
4. Press down firmly on the installation tool and tack weld the corners of the mounting plates. Follow the a, b, c, d sequence shown in the illustration. Use low power settings and small-gauge welding rods. Complete the welds following the same sequence. Weld only the short sides of the mounting plates.

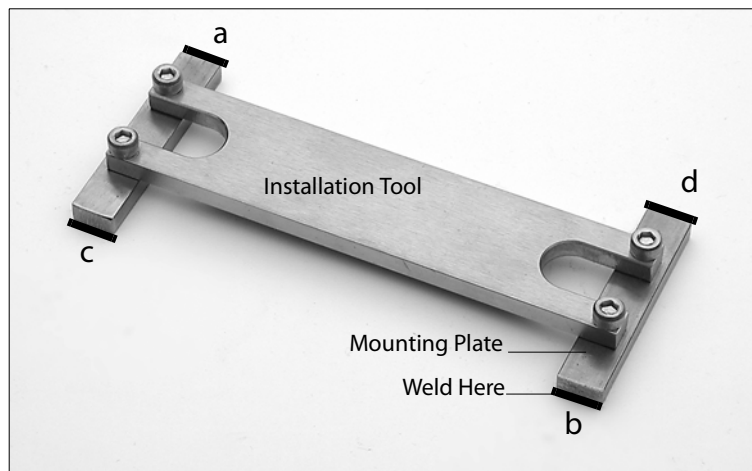

5. Remove the tool from the mounting plates. Keep the screws for use with the next gauge.
6. Check the welds, then brush the whole area to remove any dust and debris.
7. If the gauge is to be installed later or if you must restore the

---

surface coating of the structure, mask the surface of the mounting plates.

## Install the Strain Gauge

1. Remove the gauge from its transport plate. You will reuse the screws. Do not rotate the end blocks.
2. Place the gauge on the mounting plates. Insert the mounting screws and thread them all the way in, but do not tighten them.

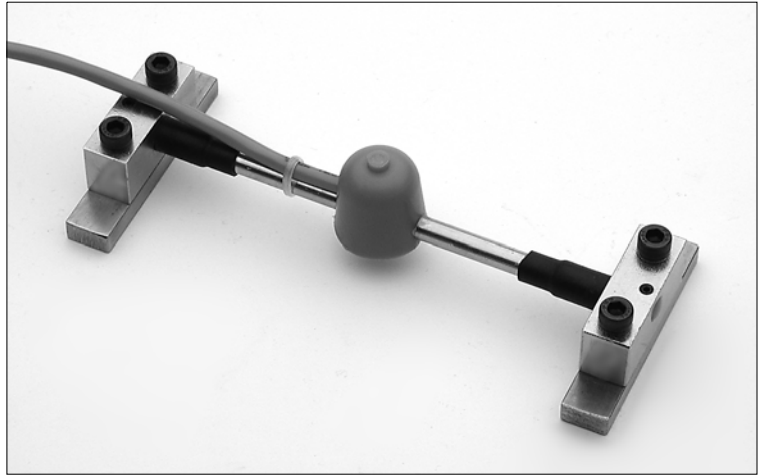

3. Progressively tighten both screws in one end block. Rotate the body back and forth slightly. It should rotate smoothly.
4. Connect a readout to the gauge. See instructions in the next chapter.
5. Gently pull or push on the second end block until the readout shows the required datum reading.

The frequency range of the gauge is 625 to 1176 Hz. Midrange is 944 Hz. If your readout is set to show  $\text{Hz}^2 / 1000$ , the equivalent values are 391 to 1383, with midrange being 891.

6. Progressively tighten the screws to fix the position of the end block. It is possible to fine-tune the datum reading by varying the sequence of tightening the screws. As you tighten the screws, check that the gauge barrel assembly still rotates.
7. Assign an ID to the gauge and note its datum reading.
8. Spray the area, including the gauge and mounting plates with a primer such as red oxide to prevent corrosion of the welds.
9. Run the cables to the intended readout station.

---

# Installation on Concrete & Masonry

**Overview** These instructions tell how to fix surface-mount strain gauges to concrete or masonry. In this type of installation, mounting plates are bonded to the surface and held in place by screws. The gauge is then screwed to the mounting plates.

In addition to the strain gauge and mounting plates, you will need two 1-inch, #6, countersunk wood screws, two wall plugs, and adhesive. You will also need a masonry drill.

**Prepare the Surface**

1. Identify the intended position and orientation of the gauge.
2. Remove any irregularities from the surface of the structure at that location. The surface should be sound, level, dry, and dust free.

**Install the Mounting Plates**

1. Confirm the location and orientation for the gauge
2. Screw the installation tool onto the mounting plates.
3. Position the plates in the intended location. Mark the center location for both screws. Set the installation tool aside.

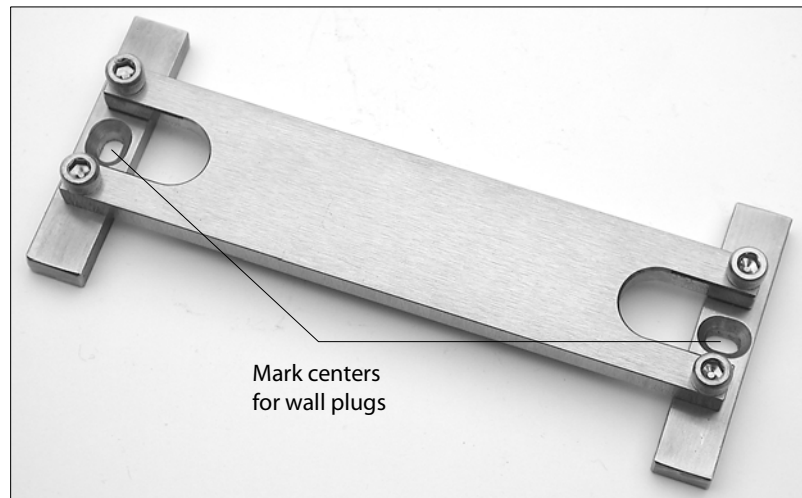

4. Drill holes for the wall plugs, and insert the plugs. Check that they are flush with or below the mounting surface.
5. Clean up the area and degrease the mounting plates.
6. Mix a sufficient quantity of adhesive, following manufacturer's instructions. Apply the adhesive to the underside of each plate to a depth of 2 or 3 mm. Also apply a small amount the surface of the structure around the wall plugs.

- 
7. With the installation tool still attached, fit the mounting plates to the structure and screw in the wood screws. Do not over-tighten the screws. Under most conditions, the adhesive will be sufficiently cured in 2 hours to allow removal of the installation tool.

## Install the Strain Gauge

1. Remove the strain gauge from the transport plate and fix loosely to the structure. Progressively tighten both screws in one end block, frequently confirming that the gauge body rotates smoothly in the end blocks.
2. Connect a readout to the gauge.
3. Gently pull or push on the second end block until the readout shows the required datum reading.  

The frequency range of the gauge is 625 to 1176 Hz. Midrange is 944 Hz. Your readout may be set to show  $\text{Hz}^2 / 1000$ , so the equivalent values are 391 to 1383, with midrange being 891.
4. Progressively tighten the screws to fix the position of the end block. It is possible to fine-tune the datum reading by varying the sequence of tightening the screws. As you tighten the screws, check that the gauge barrel assembly still rotates.
5. Assign an ID to the gauge and note its datum reading.
6. Apply weatherproofing as required.
7. Run the cables to the intended readout station.

# Taking Readings

**Introduction** These instructions tell how to read the strain gauge with Slope Indicator's portable readouts. Instructions for reading VW sensors with a CR10 data logger can be found at [www.slopeindicator.com](http://www.slopeindicator.com). Go to Support - Tech Notes. Look in the data logger section for a link titled "CR10 and VW Sensors."

**VW Data Recorder** 1. Connect signal cable to the data recorder.

Binding Posts	Wire Colors		
VW	Orange	Red	Brown
VW	White & Orange	Black	Blue
TEMP	Blue	White	Green
TEMP	White & Blue	Green	Yellow
SHIELD	Shield	Shield	Shield

2. Choose Hz<sup>2</sup> + RTD or Hz<sup>2</sup> + Thermistor, depending on which temperature device was installed.
3. Select the 450-1200 Hz range.
4. The recorder displays the sensor reading as Hz<sup>2</sup> /1000 and a temperature reading in degrees C.

**DataMate MP** These instructions tell how to use the DataMate MP in manual mode to display readings as Hz<sup>2</sup>/1000.

1. Connect signal cable to the bare wire adapter (BWA) as shown in the table below.

BWA	Wire Colors			Function
5	Blue	White	Green	TEMP
6	White & Orange	Black	Blue	VW
7	White & Blue	Green	Yellow	TEMP
8	Orange	Red	Brown	VW
10	Shield	Shield	Shield	Shield

2. Switch on. Press  (Manual Mode).
3. Scroll through the list to find "Vibrating Wire Hz<sup>2</sup>."
4. Press  to excite the sensor and display a reading in Hz<sup>2</sup> and a temperature reading in degrees C.

---

## VWP Indicator

1. Connect signal cable to the VWP indicator as shown in the tables below.
2. Select the 0.45-1.2 kHz range with the Sweep key.
3. Select Hz<sup>2</sup> with the Data key. (Do not use microstrain settings. They are for a different model of sensor).
4. Select °C with the Data key to read an RTD. Note that the VWP Indicator cannot read a thermistor.

## Standard Jumper 52611950

This cable is supplied with alligator clips:

Clips	Wire Colors			Function
Red	Orange	Red	Brown	VW
Red	White & Orange	Black	Blue	VW
Black	Blue	White	Green	TEMP
Black	White & Blue	Green	Yellow	TEMP

## Universal Jumper 52611957

This cable is supplied with a bare-wire adapter:

BWA	Wire Colors			Function
5	Blue	White	Green	TEMP
6	White & Orange	Black	Blue	VW
7	White & Blue	Green	Yellow	TEMP
8	Orange	Red	Brown	VW
10	Shield	Shield	Shield	Shield

---

# Data Reduction

- Required Data**     Calculating change in strain requires three values:
- A datum reading in Hz<sup>2</sup>/1000 (displayed by readout).
  - A subsequent reading in Hz<sup>2</sup>/1000 (displayed by readout).
  - A gauge factor.

**Calculating Change in Strain**     In the equation below, a negative value indicates compressive strain, and a positive value indicates tensile strain:

$$\Delta\mu\varepsilon = (R_1 - R_0) \times (GF)$$

Where

$R_1$  = current reading

$R_0$  = initial reading

GF = gauge factor as calculated below

If you want compressive strains represented as positive values, change the equation to:

$$\Delta\mu\varepsilon = (R_0 - R_1) \times (GF)$$

**Calculating GF**     The gauge factor is related to the length of the gauge. It can be calculated as follows:

$$GF = 0.1 \times L^2$$

Where L = Length of the wire in inches.

For example:

- If the wire has a length of 5.5", GF = 3.025.
- If the wire has a length of 250 mm, convert the length to inches (9.8425), then calculate. In this case, GF = 9.6875.

---

## Temperature Effects

We recommend that you always record temperature along with strain. Temperature data can help you understand real changes in stress due to expansion and contraction caused by temperature changes.

When the gauge is mounted on steel, there is little need to correct for differences in thermal coefficients of expansion. However, if the gauge is mounted on concrete, you may find some benefit in correcting for these differences.

## Applying a Temperature Correction

You can calculate a correction for this difference using the equation below:

$$\text{Temperature Correction} = (TC_C - TC_S) \times (T_{\text{current}} - T_{\text{initial}})$$

Where:

$TC_C$  is the thermal coefficient of expansion for concrete. A typical value is 10 ppm per °C.

$TC_S$  is the thermal coefficient of expansion for the steel wire. For this strain gauge, the coefficient is 11 ppm per °C.

T is the temperature in °C.

Apply the temperature correction according to the convention that you use:

- If you assume that compressive strain is negative, subtract the temperature correction:  $\Delta\mu\varepsilon - \text{Temperature Correction}$
- If you assume that compressive strain is positive, add the temperature correction:  $\Delta\mu\varepsilon + \text{Temperature Correction}$ .