

equotip[®] 3 swiss

Portable Hardness Tester

Operating Instructions



ISO
9001

proceq

Proceq SA

Ringstrasse 2
CH-8603 Schwerzenbach
Switzerland

Tel. +41-43-355-38-00
Fax +41-43-355-38-12
info-europe@proceq.com

Proceq USA, Inc.

117 Corporation Drive
Aliquippa, PA 15001
USA

Phone +1-724-512-0330
Fax +1-724-512-0331
info-usa@proceq.com

Proceq Asia Pte Ltd

12 New Industrial Road #02-02A
Singapore 536202
Republic of Singapore

Phone +65-6382-3966
Fax +65-6382-3307
info-asia@proceq.com

www.proceq.com

Subject to change without notice

Table of contents

1	Safety	3
1.1	General information	3
1.2	Liability	3
1.3	Safety instructions	4
1.4	Designated use	5
1.5	Applied standards and regulations	7
2	Product description	8
2.1	Field of application	8
2.2	Product features	9
2.3	Measuring method	13
2.4	Function	14
2.5	Measuring ranges	14
2.6	Application examples	16
2.7	Measuring conditions	16
2.8	Indentation size on test surface	18
3	Startup	19
3.1	Connecting the instruments	19
3.2	Starting up the unit	19
3.3	Configuration of the standby settings	20
3.4	Charging the battery	21
4	Settings	23
4.1	Keypad	23
4.2	Display	28
4.3	Preselected parameters of the EQUOTIP® 3 indicating device	29
4.4	Menu overview	30
4.5	Correction for non-vertical impact direction	46
4.6	Setting conversions to other hardness scales or tensile strength	52

4.7	Setup of plant-internal conversion curves	54
4.8	Protocol printouts	62
4.9	Memory management	71
4.10	User configurations / profiles	74
4.11	Help system	81
5	EQUOLINK3 evaluation software	82
5.1	Description and properties	82
5.2	Installing EQUOLINK3	83
5.3	First connection between EQUOTIP [®] 3 and the PC	86
5.4	Working with EQUOLINK3	88
5.5	Software upgrade	98
5.6	EQUOLINK3 help	103
6	Operation	104
6.1	Preparation of the sample	104
6.2	Triggering the impact	108
6.3	Conversion deviations	112
6.4	Calculating the mean of hardness values	114
7	Maintenance, storage and care	115
7.1	Performance check (before each use)	115
7.2	Maintenance	117
7.3	Storage	120
7.4	Cleaning (after each use)	120
8	Troubleshooting	122
9	Parts & accessories	125
9.1	Ordering information	125
9.2	Impact devices	126
9.3	Test blocks	129
9.4	Support rings	130
9.5	Technical data	134

1 Safety

1.1 General information

These operating instructions contain important information on the safety, use and maintenance of the hardness tester and its components. The purpose of the operating instructions is to protect you, prevent damage to the device and allow trouble-free operation.

- ▶ Read through these operating instructions carefully before the first use of the device.
- ▶ Keep the operating instructions in a safe place.

1.2 Liability

Our "General Terms and Conditions of Sale and Delivery" apply in all cases. Warranty claims arising from personal injury and damage to property cannot be upheld if they are due to one or more of the following causes:

- Failure to use the hardness tester and its components in accordance with its designated use.
- Incorrect performance check for operation and maintenance of the hardness tester and its components.
- Failure to adhere to the sections of the operating instructions dealing with the performance check, operation and maintenance of the hardness tester and its components.
- Unauthorized structural modifications to the hardness tester and its components.
- Serious damage resulting from the effects of foreign bodies, accidents, vandalism and force majeure.

1.3 Safety instructions

1.3.1 General information

- ▶ Perform the prescribed maintenance work on schedule.
- ▶ Carry out a performance check once the maintenance work has been completed.
- ▶ Properly handle and suitably dispose of cleaning agents.

1.3.2 Unauthorized operators

The hardness tester and its components are not to be used by children or anyone under the influence of alcohol, drugs or medication.

Anyone who is not familiar with the operating instructions should not use the hardness tester and its components or must be supervised when using it.

1.3.3 Labeling in the manual

The following icons are used in conjunction with all important safety notes in these operating instructions.



DANGER

Dangers that can lead to severe injuries or death.



WARNING

Dangers that can lead to severe injuries or considerable damage to property.



CAUTION

Dangers that can lead to injuries or damage to property.

CAUTION

Dangers that can lead to slight damage to property.



NOTE

This denotes important information.

1.4 Designated use

- ▶ Only utilize the unit according to its designated use.

EQUOTIP® 3 is for testing the hardness of surfaces quickly and independently. The hardness tester measures the Leeb hardness (HL) using the rebound method according to Leeb. Conversions of the determined Leeb hardness to other (static) hardness values (see p. 112) are programmed for the following hardness values: Brinell (HB), Vickers (HV), Rockwell (HRA, HRB, HRC), Shore (HS) for metal and tensile strength for steel (Rm). The manufacturer is not liable for damage caused by improper use or incorrect operation.

- ▶ Only use the device to measure surface hardness.
- ▶ Never carry out unauthorized conversions or modifications to the device.
- ▶ Only replace faulty components with original Proceq spare parts.
These are the only parts that are guaranteed to fulfil the safety requirements to the full extent.

- ▶ Only connect or install accessory parts when they have been expressly approved by Proceq.
If other parts are connected or installed, claims and / or product liability will be forfeited.
- ▶ Observe the operating instructions and regulations.
Otherwise, the manufacturer's warranty obligation will not apply.



CAUTION

Samples that are too hard

Damage to the impact body tip.

- ▶ Do not use on hard metals or ceramics.
- ▶ Make sure that the hardness of the sample does not exceed the following hardness values:
 - 890 HLD (955 HV, 68 HRC) for impact devices D, C, DL, S, E
 - 960 HLC (1010 HV, 70 HRC) for impact device C
 - 750 HLG (645 HB) for impact device G



CAUTION

Indentation points from hardness measurement

Testing leaves marks on the sample.

- ▶ Observe the values listed in the chapter "Indentation size on test surface" (see p. 18).



NOTE

Properly dispose of the Lithium-Ion battery

Batteries cause environmental pollution.

► For recycling bring the rechargeable batteries back to the supplier.

1.5 Applied standards and regulations

- ASTM A956-02 USA
- DIN 50156-1/2/3 Germany
- DIN EN ISO 18265:2003 International

2 Product description

2.1 Field of application

The hardness tester EQUOTIP® 3 is designed for testing metallic materials, the hardness of which ranges from very low to very high values. Hardness testing can be performed directly on-site and in any position. Typical applications for the EQUOTIP® instruments are large, heavy workpieces which could only be transported to a hardness testing machine in a laboratory with great difficulty. It is especially suitable for applications in which standard indentation hardness testing is either not feasible or not economical.

The hardness tester EQUOTIP® 3 comprises an indicating device and an impact device. It is based on the rebound hardness testing method according to Leeb. It is for testing the hardness of all material surfaces over a large range of hardness quickly and independently.

The unit displays in the hardness scales of:

- Leeb (HL)
- Vickers (HV)
- Brinell (HB)
- Rockwell (HRA, HRB, HRC)
- Shore (HS)
- Tensile strength for steel (R_m)
- Customer-specific conversion

Dynamic L-values are converted to equivalent static hardness values, e.g. HV, HB and HRC, with a certain conversion scattering (see p. 112).

2.2 Product features

2.2.1 Electronic indicating device



Fig. 2.01 Electronic indicating device

- | | |
|--------------------|------------------------|
| 1 Status LED | 5 Impact device type D |
| 2 ON / OFF key | 6 Battery compartment |
| 3 Connection ports | 7 Keypad |
| 4 LCD display | |

The electronic indicating device EQUOTIP[®] 3 represents a user-friendly microprocessor-controlled measuring system characterized by the following benefits:

- Calculation of mean value, standard deviation and range
- Impact direction automatically detected and corrected (after calibration), high measuring accuracy in every impact direction, convenient measurement in any position

- Type of impact device automatically identified, backwards compatible with older impact devices
- Fast measurement, display and storage of measured hardness values
- Integrated conversion of the measured values to other popular hardness scales
- Large measuring range
- Online transfer of the measured data to PC or laptop via USB and Ethernet interface
- Network-compatible, IP address configuration (Static or DHCP)
- RS232 and USB interface for direct connection to a printer
- Comprehensive data storage and handling:
 - Evaluation software EQUOLINK3 for further processing
 - Directory structure (file explorer)
 - Context-sensitive online help system
 - Password protected user profiles / device configuration
 - Alphanumeric text input
- Multiple display languages
- Visual and audible error messages
- Adjustable backlight

2.2.2 Functional description of the impact device

Drawing shows status at the moment of triggering the impact (impact device loaded / ready for impact).

The impact device is not a user serviceable part. The drawing is provided only for operational reference.

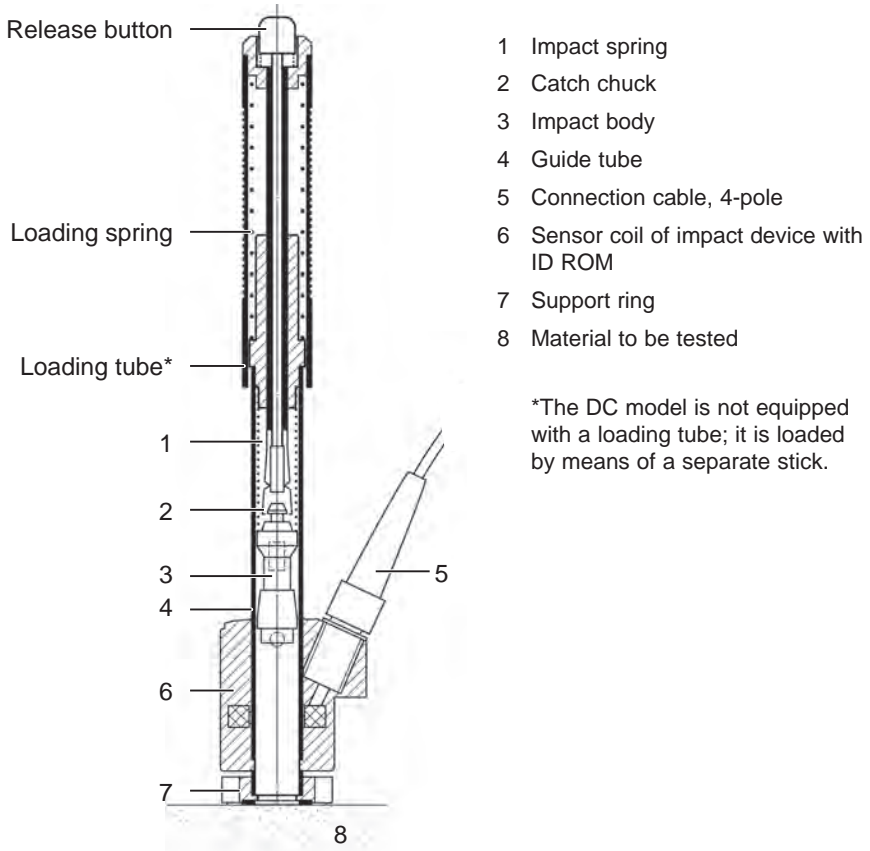

Fig. 2.02 Section of impact device



CAUTION

Disassembling the impact device

The devices should not be disassembled; disassembly may cause misadjustments resulting in inaccurate measurements.

2.2.3 Scope of delivery



Fig. 2.03 Scope of delivery, basic unit

- | | | | |
|---|---|---|--|
| 1 | EQUOTIP® 3 Indicating device
(includes rechargeable battery) | 3 | USB cable |
| 2 | USB memory stick:
- Operating instructions
- Firmware
- EQUOLINK3 PC-data evaluation
software
- Training video | 4 | Power supply unit (AC adapter) |
| | | 5 | Operating instructions |
| | | 6 | Carrying case
Quick reference guide |

The basic unit is combined with the following items to create the EQUOTIP® 3 **unit D**:

- EQUOTIP® impact device D
- Test block D with conversion of the calibrated values in HRC (mean value), Proceq calibration
- Coupling paste
- Cleaning brush
- Support ring D6 and D6a
- Calibration certificate

The basic unit is combined with the following items to create the EQUOTIP® 3 **unit G**:

- EQUOTIP® impact device G
- Test block G with conversion of the calibrated values in HB (mean value), Proceq calibration
- Cleaning brush
- Calibration certificate

For part numbers, other impact devices, test blocks and accessories as offered options to the basic EQUOTIP® 3 kit see p. 125.

2.3 Measuring method

The EQUOTIP® method is a dynamic method based on the principle of energy measurement. The ratio of the rebound velocity v_r to the impact velocity v_i multiplied by 1,000 yields the hardness value HL (Leeb hardness). HL is a direct measure of the hardness.

2.4 Function

During measurement with EQUOTIP® 3, an impact body with a hard tip is impacted by spring energy against the sample to be measured and then rebounds. During the impact, a permanent magnet integrated in the impact body passes through a coil in which voltage is induced by the forwards and backwards movement. This voltage is proportional to the velocities. The impact and rebound velocity is measured when the impact body tip is approx. 1 mm (0.04 inches) away from the sample to be measured. The measuring signal is converted to the hardness value by the unit electronics, shown in the display and stored in the unit memory (if set to store).

2.5 Measuring ranges

The EQUOTIP® 3 basic unit can be combined with any impact device to accommodate specific testing needs. Special impact devices are available for use in confined spaces, with special component geometry or surface finish.

Conversions from HL to other hardness scales

Material group*	Hardness test method	Impact device						
		D/DC	DL	G	E	S	C	
1 Steel and cast steel								
Vickers	HV	81-955	80-950		84-1211	101-960	80-1012	
Brinell	HB	81-654	81-646	90-646	83-686	101-640	81-694	
Tensile strength	N/mm ² σ 1	271-2193	271-2193	271-2193	271-2193	271-2193	271-2193	
		σ 2	619-1477	619-1477	619-1477	619-1477	619-1477	619-1477
		σ 3	451-846	451-846	451-846	451-846	451-846	451-846
Rockwell	HRC	20-68	21-68		20-72	22-70	20-70	
	HRB	38-100	37-100	48-100				
	HRA				61-88	61-88		
Shore	HS	30-100	31-97		30-103	28-103	30-102	
2 Cold worktool steel								
Vickers	HV	80-900	80-905		82-1009	104-924	98-942	
Rockwell	HRC	21-67	21-67		23-70	21-68	20-67	

Material group*	Hardness test method	Impact device					
		D/DC	DL	G	E	S	C
3 Stainless steel and high-temperature resistant steel							
Vickers	HV	85-802			87-861	119-934	
Brinell	HB	85-655			88-668	105-656	
Rockwell	HRC	20-62			19-64	21-64	
	HRB	47-102			49-102	70-104	
4 Cast iron, lamellar graphite GG							
Brinell	HB	90-664		92-326			
Vickers	HV	90-698					
Rockwell	HRC	21-59					
5 Cast iron, nodular graphite GGG							
Brinell	HB	95-687		127-364			
Vickers	HV	96-724					
Rockwell	HRC	21- 61					
6 Cast aluminum alloys							
Brinell	HB	19-164		19-168	23-176	20-184	21-167
Vickers	HV					22-196	
Rockwell	HRB	24-85		24-86			23-85
6.1 Alu-AN 40							
Brinell	HB	31-176					
7 Copper / zinc alloys (brass)							
Brinell	HB	40-173					
Rockwell	HRB	14-95					
8 CuAl / CuSn alloys (bronze)							
Brinell	HB	60-290					
9 Wrought copper alloys, low alloyed							
Brinell	HB	45-315					

* Suitability of specific materials for each group on request. Main materials for each group can also be accessed by referencing the context sensitive help menu.

2.6 Application examples

- Hardness tests on already assembled machines or steel and cast constructions; e.g. on heavy and large work pieces or on permanently installed system parts.
- Rapid testing at many measuring points to examine the hardness over large areas.
- Control measurement for the rapid determination of a specific thermal treatment result; e.g. annealed or quenched and tempered conditions.
- Testing of workpieces for which the test indentation should be as small as possible on sharp edges; e.g. on rolls or grinded surfaces of machine parts.
- Automatic hardness tests of mass-produced parts during manufacturing operation; e.g. automotive industry.

2.7 Measuring conditions



CAUTION

Surface deformation

Damage to the unit and faulty measured values.

- ▶ Make sure that no heat or surface deformations occur at the testing point during the testing process.



CAUTION

Insufficiently fastened samples

Incorrect measured values.

- ▶ Special measures must be taken for specimens that weigh less than 5 kg (11 lbs) (see p. 106).

In order to avoid erroneous measurements:

- ▶ Ensure that the surface of the workpiece is clean, smooth and dry.
- ▶ Ensure that the specimen is immobile and not subject to vibrations during the test (due to the dynamic functioning of the hardness testing method). Thin parts must be specially fastened (see p. 106).
- ▶ Use samples with large dimensions and enough mass if possible.
- ▶ Recommendation: Carry out at least 3 to 5 impacts at spaces of at least 3 to 5 mm (0.12 to 0.20 inches) at each measuring point (see p. 114) and use the average of the individual values.
- ▶ Do not carry out an impact in an area that has already been deformed by another impact.

The roughness of the finished surface should not exceed the following values:

Impact devices type	Roughness measure	
	R_t	$R_a = CLA = AA$
D, DC, DL, E	10.0 μm / 400 μin	2.0 μm / 80 μin = N7
G	30.0 μm / 1,200 μin	7.0 μm / 275 μin = N9
C	2.5 μm / 100 μin	0.4 μm / 16 μin = N5

Legend:

- R_t = Roughness depth (DIN 4762)
- R_a = Average roughness value (Germany)
- CLA = Center line-average value (Great Britain)
- AA = Arithmetical average (USA)
- N5,N7,N9 = Roughness classification according to ISO/R 1302

When preparing the surface, please observe that the condition of the material may be affected (e.g. due to heating or cold working). As a consequence, the hardness is also influenced. If the surface is inadequately prepared, the measuring results can be affected as follows:

- Excessive surface roughness results in lower L-values (the true hardness is greater than indicated) and broad variations of individual measurements
- Cold-worked surfaces produce excessively large L-values (the actual hardness is less than measured)

2.8 Indentation size on test surface

Impact device D	Diameter	Depth
At 570 HLD (300 HV, 30 HRC)*	0.54 mm (0.021 µin)	24 µm (950 µin)
At 760 HLD (600 HV, 55 HRC)*	0.45 mm (0.018 µin)	17 µm (670 µin)
At 840 HLD (800 HV, 63 HRC)*	0.35 mm (0.014 µin)	10 µm (400 µin)

Impact device C	Diameter	Depth
At 635 HLC (300 HV, 30 HRC)*	0.38 mm (0.015 µin)	12 µm (470 µin)
At 825 HLC (600 HV, 55 HRC)*	0.32 mm (0.013 µin)	8 µm (320 µin)
At 900 HLC (800 HV, 63 HRC)*	0.30 mm (0.012 µin)	7 µm (280 µin)

Impact device G	Diameter	Depth
At 535 HLG (290 HB)*	1.03 mm (0.041 µin)	53 µm (2100 µin)
At 620 HLG (410 HB)*	0.90 mm (0.035 µin)	41 µm (1610 µin)
---	---	---

* Approximate hardness conversion for steel

3 Startup

3.1 Connecting the instruments

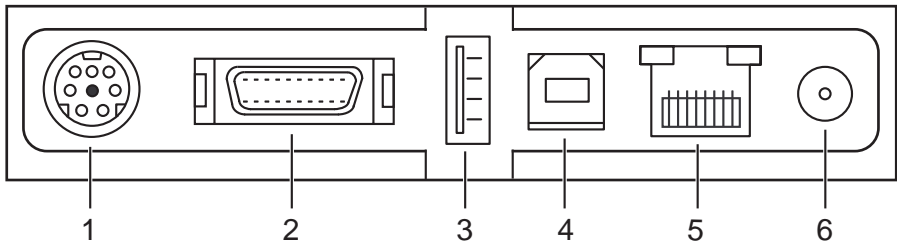

Fig. 3.01 Connection ports

- 1 RS232 connection for printer*
- 2 Input socket 20-pole for EQUOTIP® impact devices
- 3 USB port (Master) for mouse or printer
- 4 USB port (Slave) for PC
- 5 Ethernet connection
- 6 Connection power supply 12 V DC, 1.25 A

* Printer with an RS232 interface: Mini DIN to RS232 adapter cable is required,
Printer with a parallel interface: Mini DIN to RS232 and RS232 to parallel adapter
cable is required (see p. 125).

3.2 Starting up the unit

- ▶ Lift the rubber flaps to uncover the connection ports.
- ▶ Connect the impact device to the 20-pole input socket of the indicating device.
- ▶ Connect the power supply unit (12 V, 1.25 A) to the indicating device (use a connector jack with the "+ pole" in the center).
- ▶ Connect the mains connector of the power supply unit to the AC power outlet.
- ▶ Press ON / OFF key until display activates.
- ↻ While the device is booting a splash screen, the serial no. of the unit and the installed software version appear on the display.
- ↻ The type of connected impact device will be detected automatically.
- ↻ The EQUOTIP® 3 is now ready for the first measurement.

3.3 Configuration of the standby settings



Indicating device power states

To save battery power, the device supports the following power states:

State	Description
Run	The indicating device is running at full frequency.
Idle	After 3 minutes (default setting) the background illumination is switched OFF while the display continues to be active and the CPU is running at reduced frequency. This has no effects on the data or the memories. Pressing any key or performing a measurement sets the indicating device back to the run state, the illumination is switched back ON and the measured value is displayed and can be stored.
Standby	After 10 minutes (default setting) the indicating device changes to the standby mode: - Display is switched OFF completely - LED continuously flashes Pressing any key or performing a measurement sets the indicating device back to the run state and also returns to its last status. If the indicating device was reactivated by performing a measurement, the measured value will be neither displayed nor stored.
Off	The indicating device is switched OFF and consumes almost no energy. To turn it OFF, press the ON / OFF key for about 1 second. To turn it ON, press the ON / OFF key until the display activates.

The change from run to idle and standby state is controlled using time outs. A status change caused by a time out can be reset by any user activity.

The time out trigger times can be configured by the user:

- ▶ Press the  key.
- ▶ Navigate with the arrow keys (left / right) to menu item "Config".
- ▶ Navigate with the arrow keys (up / down) to submenu item "System settings".
- ▶ Open the submenu with the right arrow key.
- ▶ Navigate with the arrow keys (up / down) to the menu item "Power manager".
- ▶ Enter "Power manager" by pressing the  key.
- ▶ Navigate with the arrow keys (up / down) to the time out you want to change.
- ▶ Adjust the time out with the "+" and "-" keys.
- ▶ Close the dialog box with the  key.
- ▶ Confirm changes by selecting "Yes".

3.4 Charging the battery

Power durability

The integrated Lithium-Ion battery allows over 500 complete charge/discharge cycles to be carried out.

- ▶ Charge the battery until the status LED goes OFF.
- ↳ A fully charged battery lasts for about 10 hours.

If the power of the (rechargeable) battery is too low:

- ↳ The battery symbol flashes on the display.

If the indicating device switches OFF due to low battery power:

- ↳ No stored data will be lost (see p. 35).

Charging

- ▶ Connect the power supply unit (12 V, 1.25 A) to the indicating device (use a connector jack with the "+" pole" in the center).
- ▶ Connect the mains connector of the power supply unit to the AC power outlet.

↳ The battery will start charging.

When the indicating device is connected to a power source, the charging status of the battery is indicated by the green status LED beside the ON / OFF key:

LED state	Description
Permanently ON	A rechargeable battery is inserted and charging.
Flashing	Indicating device is in standby state. – A battery is charging ↳ LED flashes ON most of the time. – No battery is charging ↳ LED flashes OFF most of the time.
OFF	The rechargeable battery is fully charged or not inserted.

4 Settings

4.1 Keypad



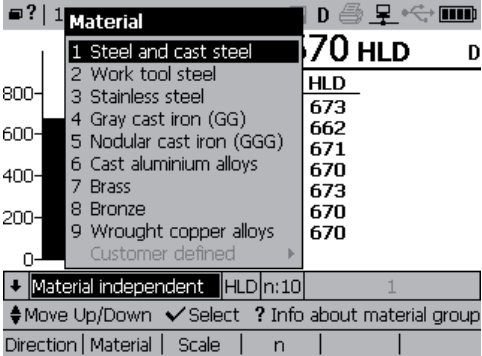

Fig. 4.01 Keypad



The keypad on the indicating device is divided into two color groups:



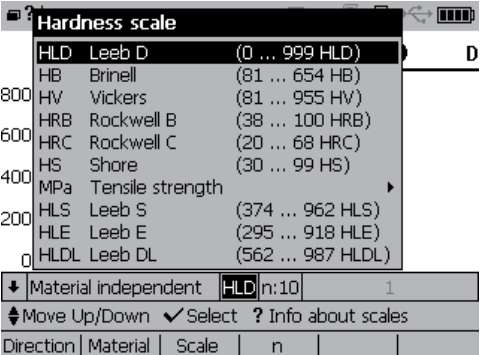

- The gray keys are context sensitive function keys (F1 to F6) and special purpose function keys (?, # etc.)
- The yellow keys are control keys for navigating through menus or dialog boxes and for confirming settings

Function keys in measure mode

	Selection of the impact direction .																
Display	<table border="1" style="margin-left: auto; margin-right: auto;"> <thead> <tr> <th>n</th> <th>HLD</th> </tr> </thead> <tbody> <tr><td>1</td><td>673</td></tr> <tr><td>2</td><td>662</td></tr> <tr><td>3</td><td>671</td></tr> <tr><td>4</td><td>670</td></tr> <tr><td>5</td><td>673</td></tr> <tr><td>6</td><td>670</td></tr> <tr><td>7</td><td>670</td></tr> </tbody> </table>	n	HLD	1	673	2	662	3	671	4	670	5	673	6	670	7	670
n	HLD																
1	673																
2	662																
3	671																
4	670																
5	673																
6	670																
7	670																
Procedure	<ul style="list-style-type: none"> ▶ Highlight the desired impact direction by using the up or down arrow key. ▶ Select by pressing the key. 																

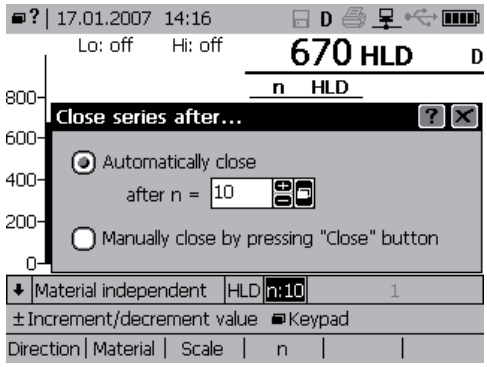
	Selection of the test material.
Display	
Procedure	<ul style="list-style-type: none"> ▶ Highlight the desired material by using the up or down arrow key. ▶ Select by pressing the  key. <p>Material selection will affect all measurements in the current measurement series (see p. 112).</p>



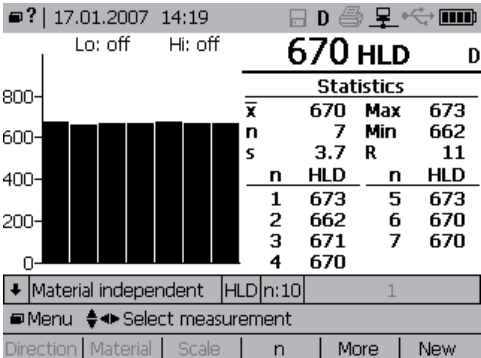

	Selection of the hardness scale.
Display	
Procedure	<ul style="list-style-type: none"> ▶ Highlight the displayed hardness scale by using the up or down arrow key. ▶ Select by pressing the  key. <p>Displayed hardness scale will affect all measurements in the current measurement series (see p. 112).</p> <p>NOTE: Changing the displayed hardness scale does not change the raw data as measured in HL.</p>

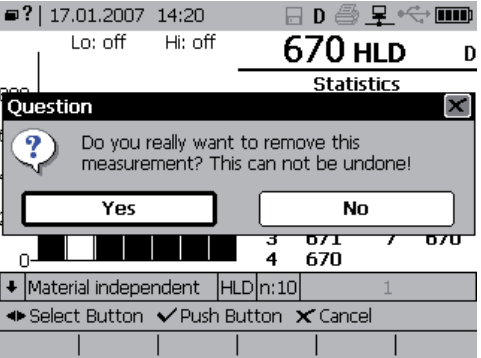
	Selection of the number of readings for a measurement series .
Display	
Procedure	<ul style="list-style-type: none"> ▶ Highlight the desired series closing method by pressing the up or down arrow key. ▶ Select by pressing the  key. <p>If selecting the automatic close feature:</p> <ul style="list-style-type: none"> ▶ Use the up or down arrow key to place the cursor in the number field box. ▶ Use the "+" / "-" keys to change the number of measurements to be taken before closing the series <p>or</p> <ul style="list-style-type: none"> ▶ Press the  button and use the software numeric keypad. ▶ Press the  key to confirm selection and to close the dialog window. ▶ Return to the measure mode by pressing the  key.







	<p>Double function: Closing and Continuing a measurement series.</p>																																				
<p>Display</p>	 <p>Lo: off Hi: off 670 HLD D</p> <table border="1"> <thead> <tr> <th colspan="4">Statistics</th> </tr> </thead> <tbody> <tr> <td>\bar{x}</td> <td>670</td> <td>Max</td> <td>673</td> </tr> <tr> <td>n</td> <td>7</td> <td>Min</td> <td>662</td> </tr> <tr> <td>s</td> <td>3.7</td> <td>R</td> <td>11</td> </tr> <tr> <td>n</td> <td>HLD</td> <td>n</td> <td>HLD</td> </tr> <tr> <td>1</td> <td>673</td> <td>5</td> <td>673</td> </tr> <tr> <td>2</td> <td>662</td> <td>6</td> <td>670</td> </tr> <tr> <td>3</td> <td>671</td> <td>7</td> <td>670</td> </tr> <tr> <td>4</td> <td>670</td> <td></td> <td></td> </tr> </tbody> </table> <p>↓ Material independent HLD n:10 1</p> <p>Menu ↕ Select measurement</p> <p>Direction Material Scale n More New</p>	Statistics				\bar{x}	670	Max	673	n	7	Min	662	s	3.7	R	11	n	HLD	n	HLD	1	673	5	673	2	662	6	670	3	671	7	670	4	670		
Statistics																																					
\bar{x}	670	Max	673																																		
n	7	Min	662																																		
s	3.7	R	11																																		
n	HLD	n	HLD																																		
1	673	5	673																																		
2	662	6	670																																		
3	671	7	670																																		
4	670																																				
<p>Description</p>	<ul style="list-style-type: none"> – Closes a measurement series and calculates the statistics ("Close" is displayed) – Continues a measurement series ("More" is displayed) <p>The measured values are only saved if the diskette symbol is displayed.</p>																																				

	<p>Double function: Removing values or starting a New series.</p>																
<p>Display</p>	 <p>Lo: off Hi: off 670 HLD D</p> <p>Question</p> <p>Do you really want to remove this measurement? This can not be undone!</p> <p>Yes No</p> <table border="1"> <thead> <tr> <th colspan="4">Statistics</th> </tr> </thead> <tbody> <tr> <td>n</td> <td>HLD</td> <td>n</td> <td>HLD</td> </tr> <tr> <td>3</td> <td>671</td> <td>7</td> <td>670</td> </tr> <tr> <td>4</td> <td>670</td> <td></td> <td></td> </tr> </tbody> </table> <p>↓ Material independent HLD n:10 1</p> <p>◀ Select Button ✓ Push Button ✕ Cancel</p>	Statistics				n	HLD	n	HLD	3	671	7	670	4	670		
Statistics																	
n	HLD	n	HLD														
3	671	7	670														
4	670																
<p>Description</p>	<ul style="list-style-type: none"> – Removes a selected or the last value ("Remove" is displayed) – Starts a new measurement series and resets all values in the current screen ("New" is displayed) <p>The measured values are only saved if the diskette symbol is displayed.</p>																

Special function keys

Key	Description
	Switches the automatic storage ON and OFF. ON: Storage number is incremented automatically and the diskette symbol is displayed.
	Switches the display of the mean value ON and OFF. ON: Mean value symbol is displayed next to the measurement value. OFF: Last measurement value is displayed.
	Defines the alphanumeric file name of the measurement series.
	Provides the online help for the current topic.
	Sets the background illumination . 5 adjustable levels.

Navigation control keys

Key	Description
	Opens the menu. (similar to MS Windows)
	Navigates through the menus.
	Selects and confirms.
	Closes dialog boxes.
	Increases values.
	Decreases values.

4.2 Display

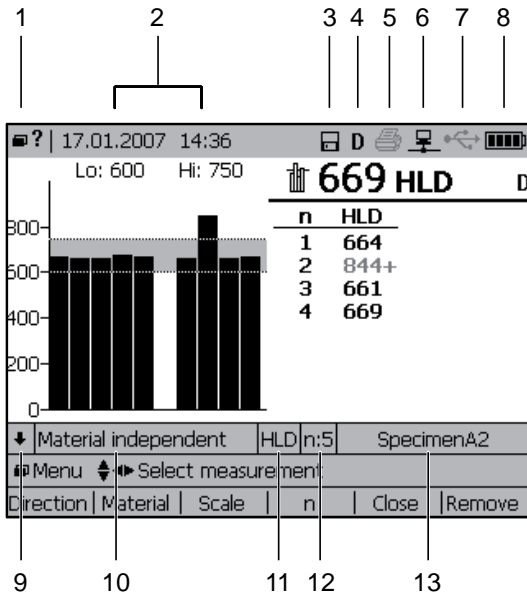

- 1 Opens menu or online help (if a mouse is connected)
- 2 Date and time
- 3 Automatic storage
- 4 Type of connected impact device (D)
- 5 Printing (not active)
- 6 Ethernet interface (ON)
- 7 USB connection to PC (not connected)
- 8 Battery state
- 9 Impact direction
- 10 Material type (independent -> No conversion)
- 11 Hardness scale (HLD)
- 12 Number of measurements in a series (5)
- 13 Name of the measurement series

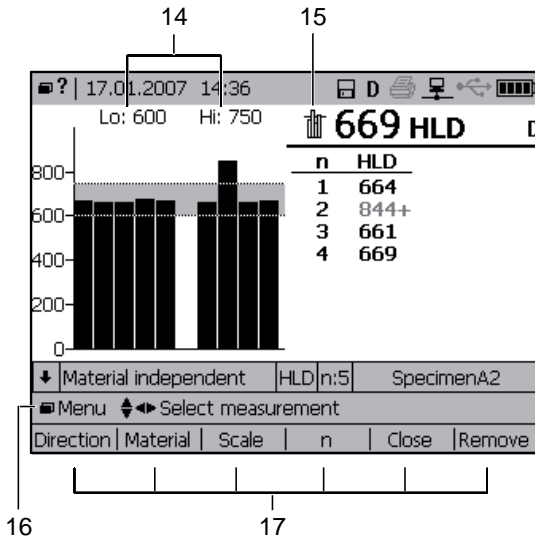

- 14 Low and high limit settings
- 15 Display of mean value
- 16 Active navigation keys
- 17 Context sensitive function keys F1 to F6

4.3 Preselected parameters of the EQUOTIP® 3 indicating device

Impact device	Automatically identified
Impact direction	Vertical down
Material	1 Steel and cast steel
Scale	HLD (if available for connected impact device type) NOTE: This is a conversion for impact device type S, E, DL.
Idle	After 3 minutes
Standby	After 10 minutes
Number of measurements	5
Automatic storage	Disabled
Signal storage	Disabled
Ethernet interface	Disabled
Measurement series file name	1
Backlight brightness	50%

4.4 Menu overview

- ▶ Press the  key.
- ↳ The main menu is opened.
- ▶ Navigate with the arrow keys through the menu items.

Structure of the menus

Main Menu				
Measurement	View	Memory	Config	Help
- Direction F1	- Bar graph	- Save series [Disk]	- Language...	- About EQUOTIP3...
- Material F2	- Basic mode	- Set series file name... #	- User interface...	- Show help index... ?
- Scale F3	- Signal graph	- Set save folder...	- Display...	- Show help content... ?
- n... F4	- Conversion function	- Explorer...	- System settings ▶	- Show system info...
- Limits...	- Display mean [x-bar]	- Properties...	- User profiles ▶	
- Close F5	- Set bar graph range...		- Signal compression...	
- Remove F6	- Multiple series bar graph		- Customer conversions ▶	
- Comment...	- Scale bar width		- Calibrate probe...	
- Print series ▶				

Legend

- Menu items labeled with "..." signify that other settings are available.
- Menu items labeled with "▶" signify that a submenu is available.

The main menu has the following submenus:

Menu "Measurement"		
Direction	F1	Selection of the impact direction.
Material	F2	Selection of the material.
Scale	F3	Selection of the hardness scale.
n...	F4	Selection of the number of values for a measurement series.
Limits...		Setting the limits for a measurement series. Values outside the limits are displayed with a "+" or "-" to the right of the measured value.
Close	F5	Double function: – Closes a measurement series and calculates the statistics (when "Close" is displayed) – Continues a measurement series (when "More" is displayed) The measured values are only saved if the diskette symbol is displayed (see p. 35).
More	F5	
Remove	F6	Double function: – Removes a selected or the last value (when "Remove" is displayed) – Starts a new measurement series and resets all values in the current screen (when "New" is displayed) NOTE: Ensure that the diskette symbol for automatic storage is displayed if the series data is to be saved.
New	F6	
Comment...		Option to write a comment to be saved with the current measurement series.
Print series	▶	Option to print two types of protocols of a measurement series or a screenshot: – Long protocol Prints all instrument and measurement series information. – Short protocol Prints only measurement series with statistics. For details see p. 64.

Menu "View"

Bar graph

Display showing the last readings of the measurement series in bar graph form. Limit values (if enabled) are displayed as a grey area in the background.

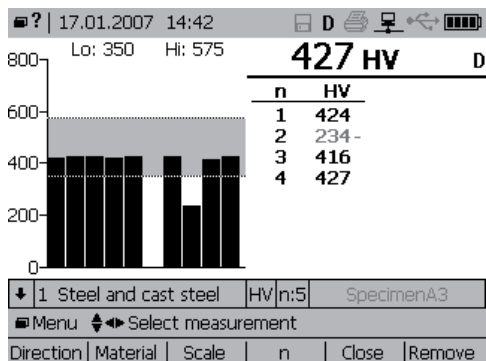

Basic mode

Measured values are displayed in large digits.

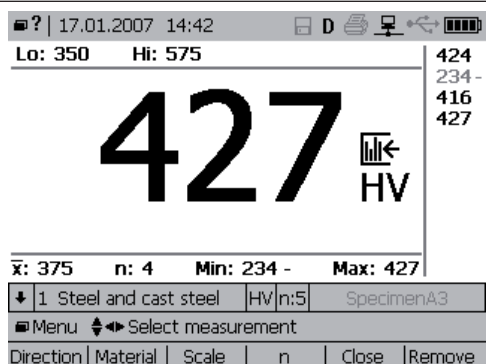

Signal graph

Displays the measurement signal from the impact device.

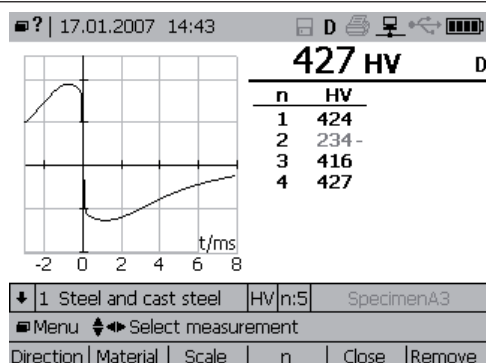

Menu "View"

Conversion function

In addition to the measured values, the current conversion curve is displayed. The measured values are shown on the graph. Limit values are displayed as horizontal lines on the graph.

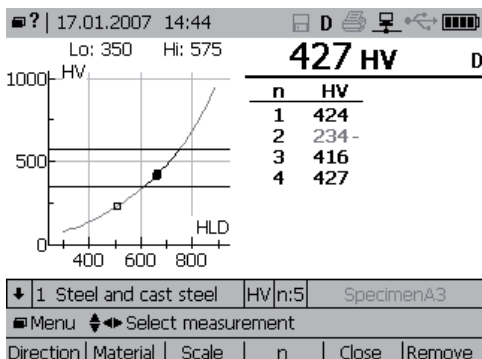

Display mean [x-bar]

The mean value is displayed as the main result when the mean function is enabled.

NOTE: The symbol for mean is displayed next to the hardness value.

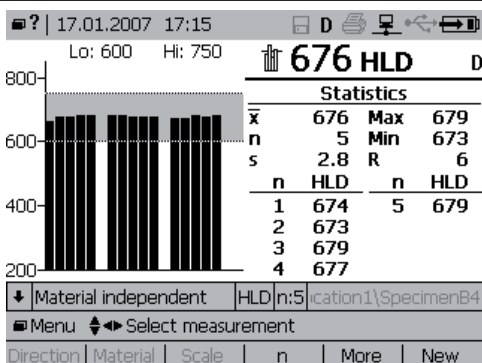

Set bar graph range...

The scale of the y-axis can be set for the bar graph view. No other views are affected by this setting.

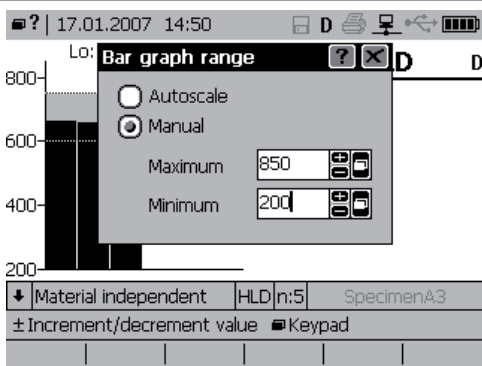

Menu "View"

Multiple series bar graph

ON: Multiple measurement series are displayed with a space in between.

OFF: Only the current measurement series is displayed.

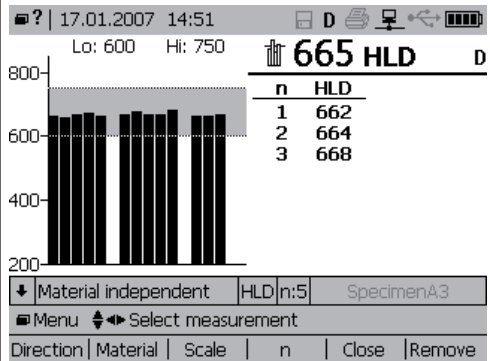

Scale bar width

ON: The bar width varies automatically according to the number of readings.

OFF: The bar width does not change. Bar width is set to display the maximum number of readings at all times.

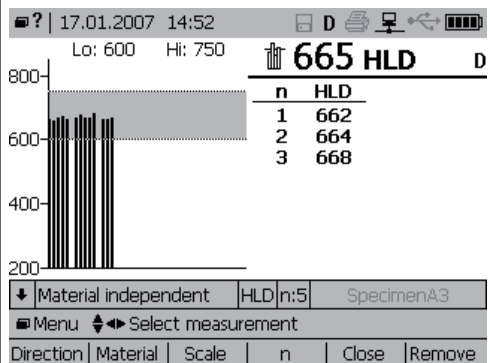

Menu "Memory"

Save series [Disk]

ON: The diskette symbol is displayed. When the set number of values for a measurement series (n) has been reached (or the series is manually closed), the current series is automatically stored. The measurement series number is incremented.

OFF: The series is not stored.

NOTE: When EQUOTIP® 3 is switched OFF with "Record" OFF, the measured data will be lost if the series has been closed.

The EQUOTIP® 3 will preserve data from an active (open) measurement series.

Series	Value
2	664
3	668
4	663

Material independent | HLD n:5 | SpecimenA3

Navigation: Select Close

Direction | Material | Scale | n | More | New

Set series file name...

Possibility to change the name of the measurement series.

NOTE: The EQUOTIP® 3 record function must be turned on for this function to be enabled.

17.01.2007 14:55

Enter series filename

SpecimenA3

A	B	C	D	E	1	2	3
F	G	H	I	J	4	5	6
K	L	M	N	O	7	8	9
P	Q	R	S	T	-	0	+
U	V	W	X	Y	Z	=	#
()				.	,	:

Navigation: Insert letter

ABC | abc | ;[]&% | | Delete

Menu "Memory"

Set save folder...

The folder for automatic data storage can be set.

Directories can be created, modified or deleted (after confirmation).

The root directory "EQUOTIP 3 (\)" is protected and cannot be deleted or changed by the user.

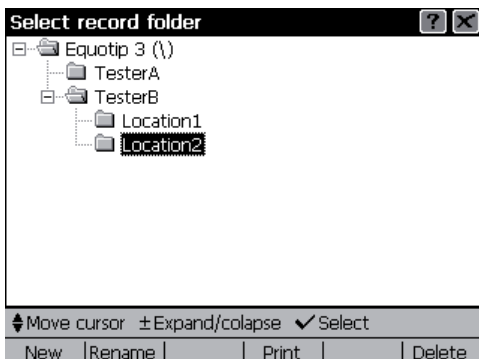

Explorer...

The EQUOTIP® 3 explorer is used to configure and manage the internal data storage (see p. 71).

Commands are programmed and assigned to the function keys F1 to F6.

NOTE: The assignment of the function keys changes depending on the current menu.

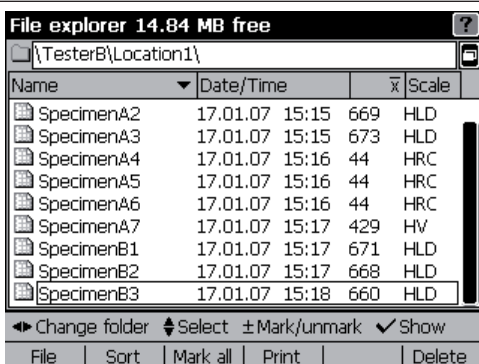

Properties...

Displays information about storage status as well as the number and type of files.

- "meas. files": the stored measurement series
- "help files": the files which establish the online help system
- "language dlls": the available languages of the application software
- "Curves": the stored customer conversion curves
- "Others": other stored data like application upgrades, logfiles etc.

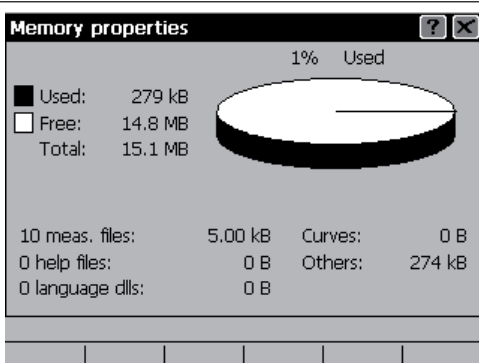

Menu "Config"

Language...

Language of the application software and the online help can be selected.

The arrow keys will cycle between the operating language and help language. Active keys and their function will be shown on the hint line at the bottom of the display.

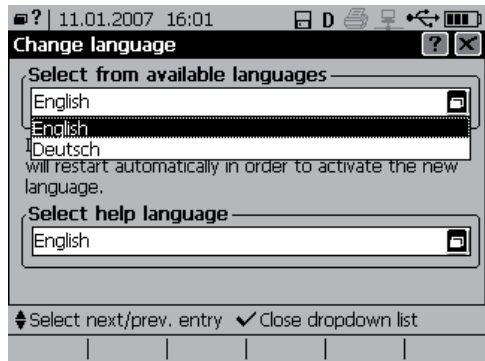

User interface...

The interface preferences can be configured independently for each individual user.

It is possible to select Keyboard or SMS style as for text input. Individual check box features are changed by using the arrow keys to scroll and highlight the feature, the key to enable (box filled) or disable (empty box) the feature (see p. 74).

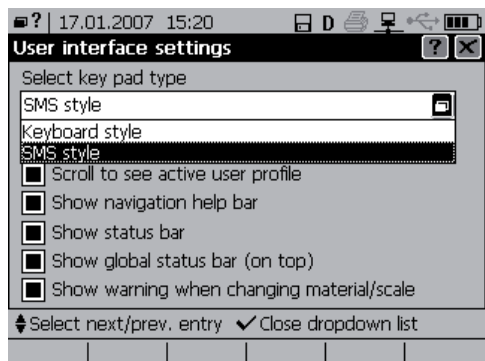

Display...

Background illumination and display contrast can be set.

► Press the arrow keys to move between the backlight and contrast controls.

The settings can be changed by scrolling with the "+" and "-" keys, or by pressing the key.

The key presents a dialog box where values can be input directly.

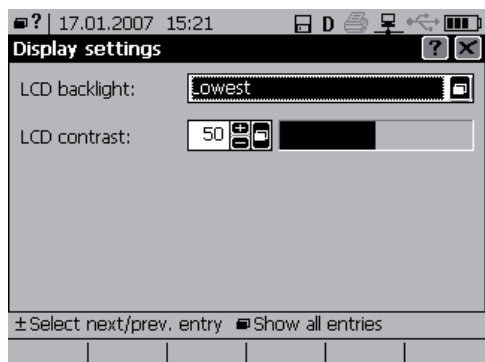

Menu "Config" / "System settings" ▶

Printer...

Different printers can be selected. The properties of the selected item can be set with the "+" and "-" keys, or by pressing the  key and selecting from the drop-down list.

For printer selection use:

- "HP PCL3 compatible" for all HP laserjet and PCL emulation compatible printers
- "Martel 9800" for the Martel 9800 thermal printer
- "Seiko DPU-201/245" for the Seiko DPU-201 or DPU-245 (Mode A) thermal printer
- "EPSON ESC/P compatible" for ESC/P emulation compatible printers with 60x60 DPI
- "EPSON 9-pin ESC/P" for ESC/P emulation compatible printers with 60x72 DPI
- "PJL->PCL emulation" to switch a printer in PJL emulation to PCL emulation and print in PCL

For more details see p. 62.

Printer configuration

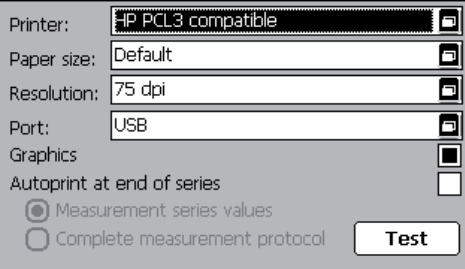

Printer:

Paper size:

Resolution:

Port:

Graphics

Autoprint at end of series



Measurement series values

Complete measurement protocol

± Select next/prev. entry Show all entries

Date & time...

Time, date and format for time/date display is set here.

- ▶ Move between the 2 tabs with the F1 or F2 key.
- ▶ Use the arrow keys to move between features within each tab.
- ▶ Use the  key to activate drop down lists.
- ▶ Move through the lists with the arrow keys.
- ▶ Select by pressing the  key.
- ▶ Use the "+" and "-" keys to scroll through the possible selections and to set the values.

The active setting for the local time in comparison with the Coordinated Universal Time (UTC) is shown at "Current date and time".

17.01.2007 15:23

Date/time properties

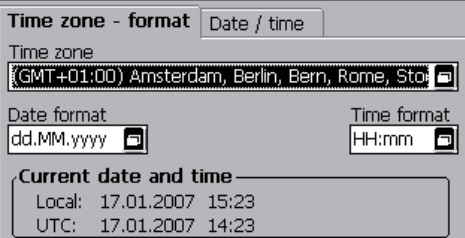

Time zone - format

Time zone

Date format

Time format

Current date and time

Local: 17.01.2007 15:23

UTC: 17.01.2007 14:23

± Select next/prev. entry Show all entries

← Tab | Tab →

Menu "Config" / "System settings" ▶ "

IP settings...

IP address of the device for network operation can be set:

▶ Enable Ethernet.

The Ethernet connector can be enabled / disabled by highlighting "Enable Ethernet" and pressing the  key.

▶ Select "Use DHCP" if the IP address is to be assigned automatically by the network

or

▶ Select "Use static IP" if the IP address is to be manually assigned.

▶ Use the arrow keys to move between values.

▶ Use the "+" and "-" keys to change values.

Check with the network administrator if the configuration of the Ethernet connection is uncertain.

NOTE: For saving power, disable Ethernet if a network operation is not necessary.

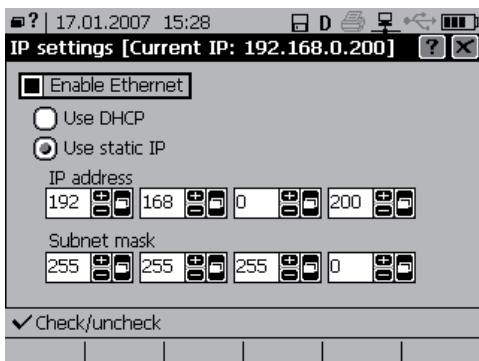

The screenshot shows the "IP settings" menu with a title bar indicating the current IP is 192.168.0.200. The menu is divided into two sections: "Enable Ethernet" and "Use static IP". The "Enable Ethernet" option is currently selected with a checkmark. Below it, the "Use DHCP" option is unselected, and the "Use static IP" option is selected with a radio button. The "IP address" field is set to 192.168.0.200, and the "Subnet mask" field is set to 255.255.255.0. At the bottom, there is a "Check/uncheck" option which is currently checked.

Power manager...

Energy consumption of the (rechargeable) battery and standby time for the indicating device to switch into a power saving mode can be set.

– Idle mode turns OFF the backlight and puts the CPU in a power conserving mode

– Standby mode turns the LCD completely OFF, but leaves the CPU in a power conserving mode (see p. 20)

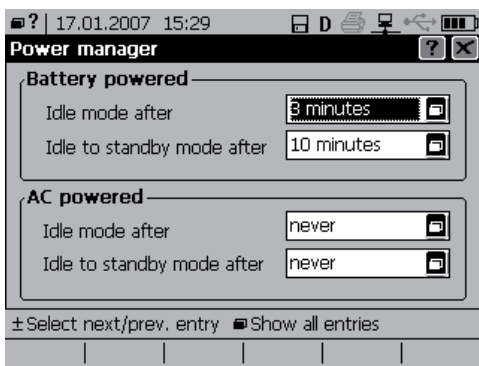

The screenshot shows the "Power manager" menu with a title bar indicating the current time is 15:29. The menu is divided into two sections: "Battery powered" and "AC powered". Under "Battery powered", the "Idle mode after" setting is set to 3 minutes, and the "Idle to standby mode after" setting is set to 10 minutes. Under "AC powered", the "Idle mode after" setting is set to never, and the "Idle to standby mode after" setting is set to never. At the bottom, there are two options: "Select next/prev. entry" and "Show all entries".

Menu "Config" / "System settings ▶"

Sound...

The EQUOTIP® 3 can be configured to sound different audible alarms for different events. The user can select a factory defined alarm scheme by choosing from the scheme pick list, or sounds can be configured on an individual basis for each event. New sound schemes cannot be created.

- ▶ Click the "Set factory defaults" button to reset the individual sound settings.

Event	Melody
Error	Error
Warning	Warning
Info popup	Beep low
Meas. ok	Meas. ok short
Meas. failed	Meas. failed short
Key press	No sound
Wrong key press	No sound

Menu "Config" / "User profiles ▶"

Change user...

The active user is changed through this menu item (see p. 75).

- ▶ Press the  key to expand the choices.
- ▶ Scroll with the arrow keys to select the desired user profile
- or
- ▶ Use the "+" and "-" keys to scroll through the choices.

Choose the user profile to become active:

- <<no name>> [su] [*]
- <<no name>> [su] [*]
- Smith [su]
- John Doe [su]



Menu "Config" / "User profiles" ▶

User profiles...

User profiles are managed with this menu selection (see p. 75).

- ▶ Select the profile to be changed by using the "+" or "-" key to scroll through the profiles

or

- ▶ Use the  key to expand all the choices and select with the arrow keys.
- ▶ Enable / disable super user rights by highlighting the text and pressing the  key.

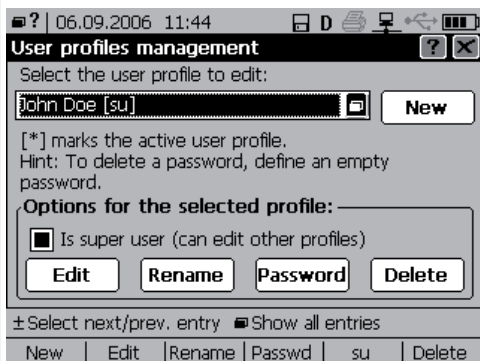

Buttons:

- "New": Creating a new user profile and opening the access rights dialog (see next menu item)
NOTE: Only super users can open this dialog
- "Edit": Changing the access rights of the selected user profile
- "Rename": Changing the user name of the selected profile
- "Password": Defining a password for the selected profile
- "Delete": Deleting the selected user profile
NOTE: The active profile or the last super user cannot be deleted



Access rights...

Possibility to assign access rights to the user profile which is displayed in the header. The Access rights dialog has 8 tabs that contain selections organized by category.

- ▶ Move between the tabs with the  or  key.

These rights can be used to limit access to features and settings for each individual user (see p. 76).

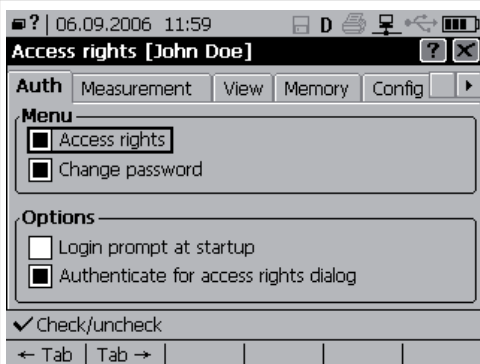

Menu "Config" / "User profiles ▶"

Change password...

This dialog allows the user to change the password for the active user profile.

The EQUOTIP® 3 will first prompt the user for the existing password. When the correct password is entered the dialog will prompt for the new password, and then ask the user to confirm the new password. Leaving the password space blank will delete the old password for the active user profile.



Menu "Config"

Signal compression...

Setting the EQUOTIP® 3 to store the signal in a lower resolution format (or not store the signal at all) will preserve more room for storage of hardness values, but may limit the ability to assess potentially bad data through signal evaluation.

A signal can be stored in different formats:

- Low compression
- Medium compression
- High compression

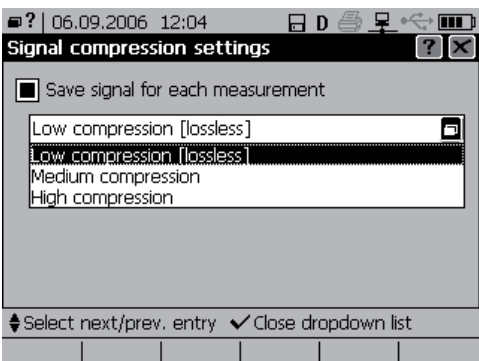

Menu "Config" / "Customer conversions ▶"

One point calibration...

One point calibration is based on a standard conversion function $H_{Std}(L)$ and shifts this vertically so that the conversion of the specified HL-value L_1 coincides with the known converted value H_1 .

For details see p. 54.

One point [SpecialSteel]
?
✕

HLD	HB	
607	363	
Range min	Range max	
200	500	

Properties

Create

± Increment/decrement value
Keypad

Prop.

Create

Two point calibration...

Two point calibration uses a standard conversion function $H_{Std}(L)$ and adds a straight line so that the resulting conversion function $H(L)$ passes through two known points $(L_1, H(L_1))$ and $(L_2, H(L_2))$.

For details see p. 57.

Two point [SpecialSteel]
?
✕

HLD	HB	
491	222	
697	490	
Range min	Range max	
150	550	

Properties

Create

± Increment/decrement value
Keypad

Prop.

Create

Polynomial specification...

With an analytical approximation function in the form of a polynomial is available for converting from the L scale of the used impact device to the required hardness scale H .

For details see p. 59.

Polynomial [SpecialSteel]
?
✕

Properties

Coefficients

Create

Range min
500
Range max
850

± Increment/decrement value
Keypad

Prop.
Coeff.

Create

Menu "Config" / "Customer conversions ▶"

Manage customer conversions...

Possibility to display, rename and delete stored customer conversions.

Material name	Probe	Scale
SpecialSteel	D	HRC
SpecialSteel	D	HB
Titanium	G	HB
Titanium	D	HB

Move selection up/down

Buttons: Rename | | | Delete

Menu "Config"

Calibrate probe...

This dialog is used for Impact device calibration for automatic impact direction correction (see p. 49).

Probe calibration [ID01-500-0013]

Do at least three measurements for each direction

Impact direction

0° (down)

90° (horiz.)

180° (up)

Manufacturer calibration

Use

	0	0	0

Buttons: Test | Undo last | Restart

✓ Select

Buttons: | Toggle | Test | Undo | Restart

Menu "Help"

About EQUOTIP3...

Information concerning the hardware revision, serial number of device and probe, the version of application software, operating system, language DLL and help system is displayed.

NOTE: The language DLL version of the active application language is displayed. If none is displayed, English is the active language.

About EQUOTIP3

Application software version: 1.0.0

Operating system version: 1.0.0

Language DLL version: ---

Help system version: 0.2b ENG

Hardware revision: A2

Device serial number: E301-000-0047

Probe serial number: ID01-500-0012

Proceq Portable Hardness Tester



Copyright © 2006 by Proceq SA

Buttons: | | | | |

Menu "Help"

Show help index... ?

The index of the online help is displayed.

- ▶ Browse through the topics by using the arrow keys.
- ▶ Display a topic by highlighting the topic and selecting it with the  button.
- ▶ Escape the help index without displaying a topic by pressing the  button.

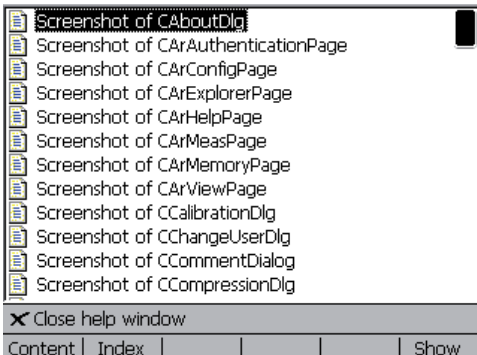

Show help content... ?

The content of the online help manual is displayed.

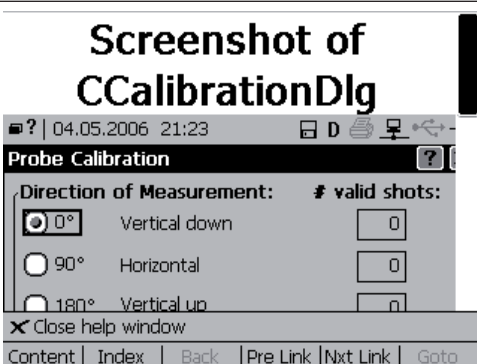

Show system info...

Information about the main battery is shown (rechargeable battery or primary cells) by default.

- ▶ Press  key "RTC Bat" to display the parameters of the real time clock battery.

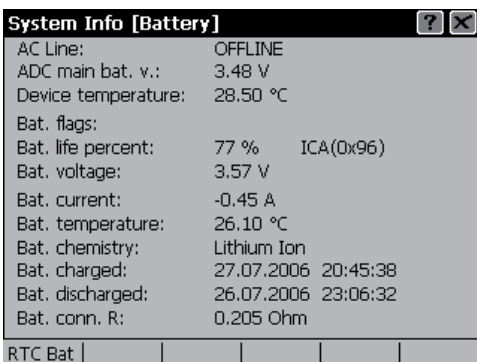

4.5 Correction for non-vertical impact direction



EQUOTIP® 3 offers two methods for correction for non-vertical impact direction: Automatic and manual. With manual correction the user has to specify the actual impact direction. In automatic mode the EQUOTIP® 3 will find out the impact direction itself and apply the appropriate correction.

NOTE

Automatic correction of impact direction

If only vertical down measurements are performed, disabling automatic correction is preferable (may result in slightly smaller measurement errors). Automatic correction is not supported for DL-impact devices and for all old impact devices connected to the EQUOTIP® 3 with an adapter cable.

Changing impact direction correction mode

- ▶ Press the  key.
- ▶ Select either "a" for automatic correction or the required impact direction.
- ▶ Confirm the selection with the  key.
- ↳ The new impact direction is set or automatic correction is enabled.

4.5.1 Testing the current impact device calibration

EQUOTIP® 3 impact devices (except type "DL") support automatic direction compensation. This compensation function relies on probe specific parameters, which are stored in the device by the manufacturer. These parameters may change with time or due to external influences.

To check if the current parameters are still valid:

- ▶ Connect impact device to indicating device (see p. 19).
- ▶ Select menu item "Config".
- ▶ Select submenu item "Calibrate probe ...".
- ▶ Click the "Test" button or press the  key.

↪ The following dialog box with a graphical representation of the calibration parameters opens:

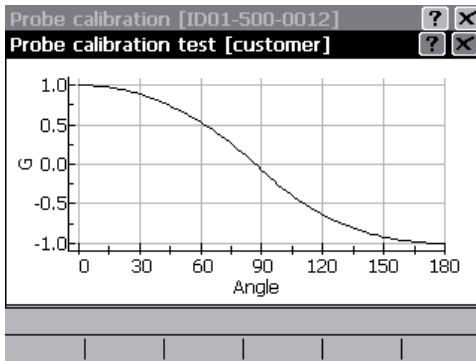
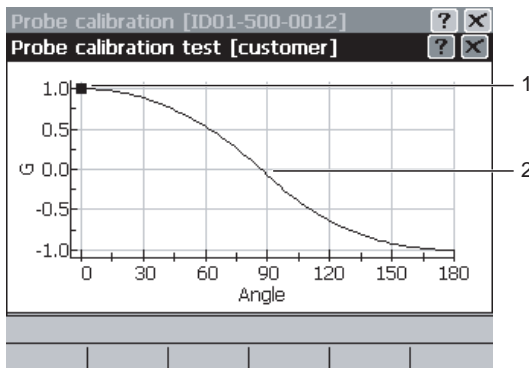

Fig. 4.02 Probe calibration test

▶ Perform a few vertical down measurements on a solid metal material and observe the measurement point marked on the curve. It should not be below $G = 0.8$:



- 1 Measurement point (vertical down)
- 2 Calibration curve

Fig. 4.03 Calibration test vertical down

- ▶ Perform a few horizontal measurements on a solid metal material and observe the measurement point marked on the curve. The G value should be in a range of ± 0.2 about the position where the curve intersects the vertical line at 90° :

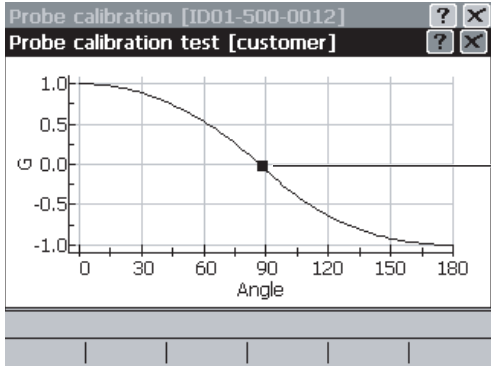

3 Measurement point (horizontal)

Fig. 4.04 Calibration test horizontal

- ▶ Perform vertical up measurements on a solid metal material and observe the marked point. The G value should not be less than $G = -0.8$:

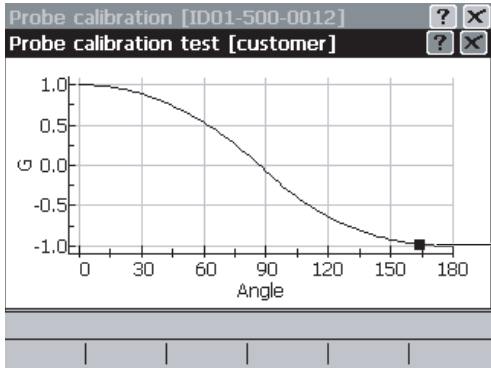

4 Measurement point (vertical up)

Fig. 4.05 Calibration test vertical up

Gravity component G

The gravity component G is an impact direction measure. It is essentially $G = \cos \theta$ where θ is the impact direction angle

($\theta = 0^\circ$: vertical down, $\theta = 180^\circ$: vertical up), slightly distorted by the influence of friction and dynamic properties of the impact device mechanics. Hence:

G = +1 indicates vertical down,

G \approx 0 horizontal and

G = -1 vertical up.

The correction to a measured HL-value depending on the impact direction is approximately proportional to $(1-G)/2$, where the (negative!) "proportionality constant" depends on the HL-value. It ranges from about -10 HL for very hard materials to -30 HL for extremely soft materials. So an error of 0.2 ($\pm 10\%$) in G corresponds to an error between 1 and 3 HL in the corrected values.

4.5.2 Impact device calibration

Probe specific parameters must be measured again if:

- The impact body has been changed
- Device calibration test as described above shows deviations greater than ± 0.2 from the curve value at the impact direction

Recalibration of the probe is recommended if:

- The impact device has been cleaned
- The impact device has not been used for a longer time
- Particular high accuracy is required

Procedure

- ▶ Connect the impact device to the indicating device (see p. 19).
- ▶ Select menu item "Config".
- ▶ Select submenu item "Calibrate probe ...".

↳ The following dialog box opens:

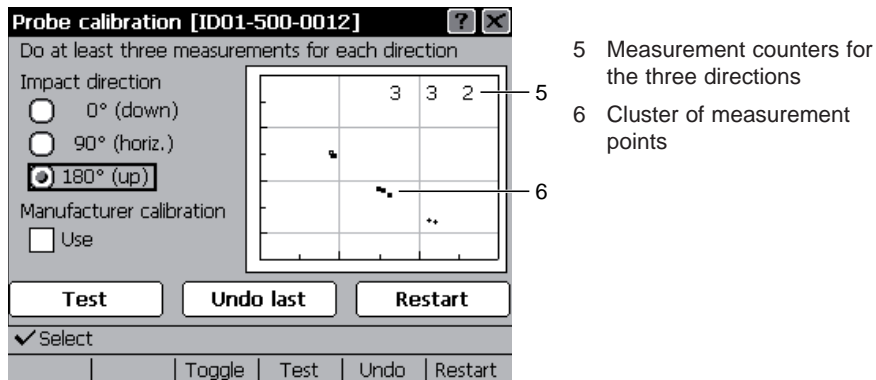

Fig. 4.06 Probe calibration

▶ Select impact direction "0° (down)" and perform at least three vertical down measurements on a solid metallic body.

↳ In the plot on the right for each measurement a dot is displayed and the left of the three numbers is increased by one. The dots should be grouped close together.

If there is an outlier:

▶ Delete it by clicking the "Undo last" button or pressing the **F5** key.

▶ Select impact direction "90° (horiz.)" and perform at least three horizontal measurements on a solid metallic body.

↳ The corresponding dots in the diagram will normally be located in a small cluster right below the 0° dots. The second number on the top of the diagram is increased by one with each measurement.

If there is an outlier:

▶ Delete it by clicking the "Undo last" button or pressing the **F5** key.

- ▶ Select impact direction "180° (up)" and perform at least three horizontal measurements on a solid metallic block.
- ↪ Another cluster of dots will be displayed in the lower right of the plot. Outliers can be removed as described above. The right most number on the top is increased by one with each measurement.
- ▶ Ensure that the "Manufacturer calibration" check box is disabled.
- ▶ Click the "Test" button or press the  key to check the calibration.
- ↪ The "Probe calibration test" dialog opens.
- ▶ To check the calibration function see the previous section 4.5.1.



NOTE

Correction function



If the intersection point of the correction function curve with the vertical 90° line is considerably below $G = 0$ ($G(90^\circ) < -0.3$), the impact body is probably decelerated by excessive friction.

- ▶ Clean the impact device and repeat the calibration procedure.

If the problem persists, the impact device mechanics may be worn out.

- ▶ Press the  key to close the test dialog.
- ↪ The test dialog is closed and the "Probe calibration" dialog opens again.

If the calibration procedure has to be repeated:

- ▶ Click the "Restart" button or press the  key.
- ↪ All measured data is deleted.
- ▶ Press the  key to close the „Probe calibration“ dialog.
- ▶ To save the new calibration parameters in the probe click "Yes".
- ↪ The new calibration parameters are stored in the impact device ID-ROM.

4.6 Setting conversions to other hardness scales or tensile strength

In the indicating device, a number of tables for converting dynamic hardness values HL to standard hardness scales such as HV, HB, HRC, HRB, HRA are integrated (see p. 14).

For comparison between HL hardness values and other hardness scales, measurements are carried out on a large number of test pieces, from which the EQUOTIP® 3 conversion tables have been derived.



HL hardness values as direct hardness measure

With regard to a certain group of material, the HL hardness values constitute a direct hardness measure and can be used as such. This allows optimum utilization of the high accuracy of the EQUOTIP® method.

Vickers, Brinell, Rockwell, and Shore hardness scales

With a certain loss of accuracy (conversion deviation), Leeb hardness values can be converted into equivalent hardness values of other hardness measuring methods such as Brinell, Vickers, Rockwell C, Shore, etc. These conversions can be selected in the indicating device (see p. 24).

Changing the hardness scale

- ▶ Ensure that the appropriate material class is selected.
 - ▶ Press the  key.
 - ▶ Select the required hardness scale.
 - ▶ Confirm selection with the  key.
- ↳ The new hardness scale is set. All displayed hardness values are shown in the new scale.

Hardness scale conversions are material specific, caused by the fact, that there is no clear physical relationship between the various methods. Care must be taken to select the proper conversion table to be used. Please refer to the online help in the EQUOTIP® 3 indicating device for a list of acceptable materials for any given material group.



CAUTION

Material dependence of conversions

If no conversion into the desired scale is available for the material to be tested, never select a different material for which the conversion is on hand! Unpredictable large conversion errors may result. Create a customer specified conversion instead (see next section).

Conversion deviations for special steel qualities

In particular, conversion deviation can occur with the following steel qualities:

High alloyed steels

In high-speed tool steels, hotwork steels, and ledeburite chromium steels (group of high-carbon cold-work steels), the hard materials embedded in the matrix (ledeburite tungsten carbide e.g. type M7C3 and M6C) cause a local increase of the E-modulus, resulting in HL-values which are actually too low. A typical representative of this group is the tool steel for cold work X210Cr12 (Material No. 1.2080) containing 2.1% C and 12% Cr.

Cold work-hardened steels

Drawn and in part also rolled steels frequently lead to excessive high HL-values due to the pronounced cold-worked regions near the surface which simulate higher than actual hardness. Such steels should always be tested over their entire cross-section.

Magnetic steels

When testing magnetic materials, the velocity transmitter in the impact body is influenced by their magnetic field. Therefore, slight deviations of the measured HL-value may occur.

Surface-hardened steels

Surface-hardened steels and especially case-hardened steels produce HL-values which are too low when the case-hardening depth is small because of their soft core.

Tensile strength

For certain steels hardness can be converted to tensile strength according to DIN EN ISO 18265:2003.

4.7 Setup of plant-internal conversion curves

Proceq provides conversion curves into standard hardness scales for a series of materials. For special solutions, or when testing materials for which no generally applicable conversions are available, it is possible for the user to create own conversion functions if:

- The material cannot be assigned to one of the classes available for the used impact device.
- The required conversion scale is not available for the impact device being used or the material class.
- Conversions display systematic deviations.

4.7.1 One point calibration

One point calibration is based on a standard conversion function $H_{std}(L)$ and shifts this vertically so that the conversion of the specified HL-value L_1 coincides with the known converted value H_1 .

$$H(L) = H_{std}(L) - H_{std}(L_1) + H_1$$

One point calibration is typically used if only one workpiece with known hardness in the required scale is available or all available reference pieces have hardness values that are grouped closely together. The workpieces to be measured are made from the same materials and their hardness differs only slightly from the reference hardness.

Procedure

Assume a reference body with a known hardness H_1 in the desired scale.

- ▶ Measure the hardness with the impact device for which the conversion should be performed in the corresponding HL scale (see chapter 6). The mean of at least 10 to 15 HL-values should be formed. The individual readings should be taken in the same area where the indentations of the standard scale measurements are located.
- ▶ Select menu item "Config".
- ▶ Select submenu item "Customer conversions...".
- ▶ Select submenu item "One point calibration...".
- ↪ The "Properties" dialog box opens.

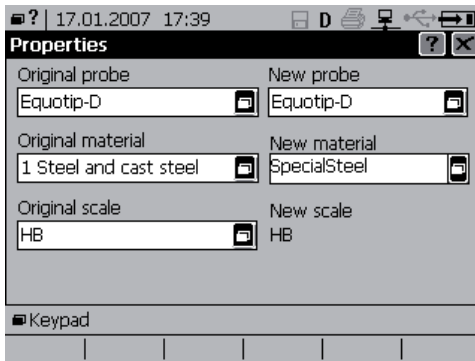

Left-hand column:

- ▶ Select the impact device for "Original probe".
- ▶ As "Original material", select a standard material (for which the required hardness scale is available) that is as similar as possible to the reference piece.
- ▶ Select the hardness scale for "Original scale".

Right-hand column:

- ▶ As "New probe", select the impact device type with which the measurement was performed previously and for which the conversion should be performed.
- ▶ "New Material" input field: Enter any name for the material.

- ↪ This name will appear later in the material selection list. The same material names should be used if conversions for one material into various scales, e.g. HV, HB and HRC or for various impact device types are created.
- ▶ Close the dialog box with the  key.
- ↪ The "One point" dialog box opens. The specified material name is indicated in square brackets.
- ↪ The selected standard conversion function $H_{std}(L)$ is sketched in the diagram.

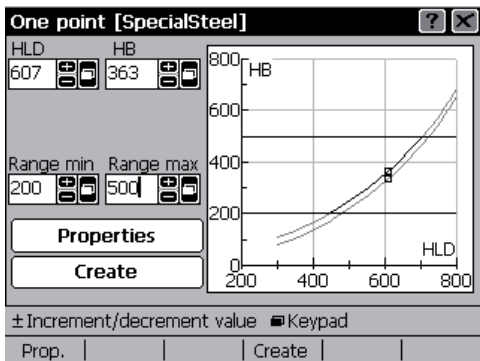

- ▶ In the input field at the top left ("HLD" in this example), enter the measured hardness L_1 in the HL scale of the probe.
- ↪ The point $(L_1, H_{std}(L_1))$ is marked in the diagram.
- ▶ In the box at the top right ("HB" in this example), enter the known hardness H_1 in the converted scale.
- ↪ The new conversion function $H(L)$ now appears in the diagram in black and the entered point $(L_1, H(L_1))$ is drawn in. The original function $H_{std}(L)$ is shown in grey.
- ▶ In the "Range min" and "Range max" input fields, enter the interval in the converted scale for which the conversion function should apply.
- ↪ The limits of the validity range are marked in the diagram by horizontal lines.



NOTE

Validity range

Only relatively small areas are recommended (corresponding to no more than ± 100 HL) for conversion functions generated using one point calibration.

- ▶ If necessary, click the "Properties" button or press the **F1** key to change the impact device type or material name. The original conversion function specification cannot be changed at that time.
- ▶ Click the "Create" button or press the **F4** key to save the created conversion function.

4.7.2 Two point calibration

Two point calibration uses a standard conversion function $H_{std}(L)$ and adds a straight line so that the resulting conversion function $H(L)$ passes through two known points $(L_1, H(L_1))$ and $(L_2, H(L_2))$.

$$H(L) = H_{std}(L) - H_{std}(L_1) + H_1 + (L - L_1) \frac{H_{std}(L_2) - H_2 - H_{std}(L_1) + H_1}{L_2 - L_1}$$

Two point calibration is typically used if at least two workpieces with known and significantly distinct hardness values in the required scale are available. The workpieces to be measured are made from the same material and are neither significantly harder than the hardest reference piece nor significantly softer than the softest reference piece.

Procedure

Two reference objects with known hardness values H_1 and H_2 in the desired scale as different as possible from one another are required.

▶ Measure the hardness values with the impact device for which the conversion should be performed in the corresponding HL scale (see chapter 6). The means of at least 10 to 15 HL-values should be formed. The individual readings should be taken in the same area where the indentations of the standard scale measurements are located.

▶ Select menu item "Config".

▶ Select submenu item "Customer conversions...".

▶ Select submenu item "Two point conversions...".

↪ The "Properties" dialog box opens.

▶ Make settings in the same way as for "One point calibration...".

▶ Close the dialog box with .

↪ The "Two point" dialog box opens. The specified material name is indicated in square brackets.

↪ The selected standard conversion function $H_{std}(L)$ is sketched in the diagram.

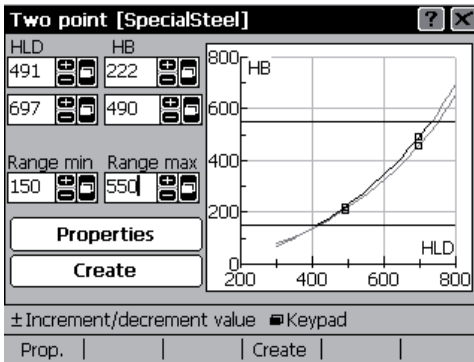

▶ In the box at the top left ("HLD" in this example), enter the measured hardness L_1 in HL of the softer of the two reference pieces.

▶ In the box at the top right ("HB" in this example), enter the known hardness H_1 in the converted scale.

▶ In the second line, enter the measured HL-hardness L_2 and the known converted hardness H_2 of the harder reference workpiece.



- ↪ The diagram now shows the original standard conversion function in grey and the modified conversion function in black. The interpolation points are marked.
- ▶ In the "Range min" and "Range max" input fields, set the interval in the converted scale for which the conversion function should apply.
- ↪ The limits of the validity range are marked in the diagram by horizontal lines.



NOTE

Validity range

We recommend not expanding the validity range to the left and right any further than half the difference between the reference hardness values.

- ▶ If necessary, click the "Properties" button or press the  key to change the impact device type and material name. The original conversion function specification cannot be changed at that time.
- ▶ Click the "Create" button or press the  key to save the created conversion function.

4.7.3 Polynomial specification

An analytical approximation function in the form of a polynomial is available for converting from the L scale of the used impact device to the required hardness scale H .

$$H(L) = A_0 + A_1L + A_2L^2 + A_3L^3 + A_4L^4 + A_5L^5$$

Procedure

- ▶ Select menu item "Config".
- ▶ Select submenu item "Customer conversions...".
- ▶ Select submenu item "Polynomial specification...".

↳ The "Create user conversion" dialog box opens:

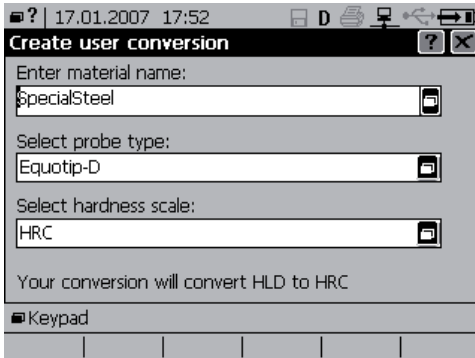

- ▶ In the "Enter material name:" input field admit any material name.
- ▶ Select the impact device in "Select probe type:" for which the conversion should apply.
- ▶ Select the conversion scale for "Select hardness scale:".
- ▶ Close the dialog box with .

↳ The "Polynomial coefficients" dialog box opens:

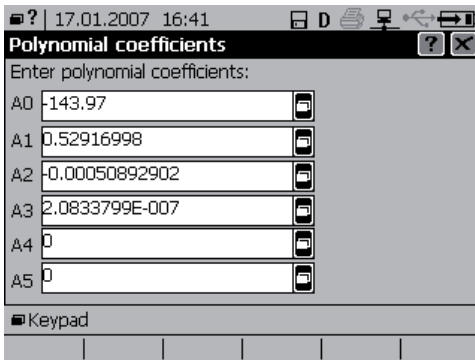

- ▶ Enter the known polynomial coefficients in the input fields:
 - A0 is the constant coefficient
 - A1 linear coefficient
 - A2 quadratic coefficient
 - etc.
- If the polynomial is of lower degree than five, the unneeded highest-order coefficients must be set to zero.

- ▶ Specify a sufficient number of decimal places. Otherwise, there may be unexpected rounding errors, depending on the structure of the polynomial. This is important with high-order coefficients in particular. By internal rounding the displayed coefficients may differ slightly from the entered numbers.



NOTE

Scientific notation

The input keypad not only makes it possible to enter digits, decimal point and change of sign ([±]) but also exponents ([E+] and [E-] keys) for scientific notation. "1.75894E-6" is identical to "0.00000175894".

- ▶ Close the dialog box with

↪ The "Polynomial" dialog box opens with the specified material name indicated in square brackets.

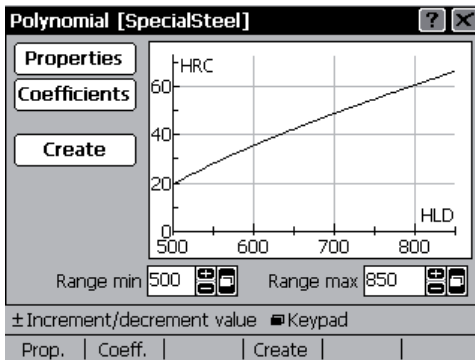



- ↪ The specified polynomial function is sketched in the diagram.
- ▶ In the "Range min" and "Range max" input fields, enter the limits of the interval (in HLx!) for which the conversion function should apply.



NOTE

Range limits

If you have obtained the polynomial function from numerical fit of measured values, the range limits should not or only slightly extend the range covered by your measurements. Extrapolation, in particular with higher-degree polynomials, can lead to surprises.

- ▶ If necessary, click the "Properties" button or press the  key to change the material name, impact device type or converted hardness scale.
- ▶ If necessary, click the "Coefficients" button or press the  key to check and change the entered polynomial coefficients.
- ▶ Click the "Create" button or press the  key to save the created conversion function.

4.8 Protocol printouts

4.8.1 Setting printer configuration

Procedure

- ▶ Connect the printer to either the USB host or the serial port of the indicating device.
- ▶ Select menu item "Config".
- ▶ Select submenu item "System settings".
- ▶ Select submenu item "Printer...".

↪ The "Printer configuration" dialog box opens:

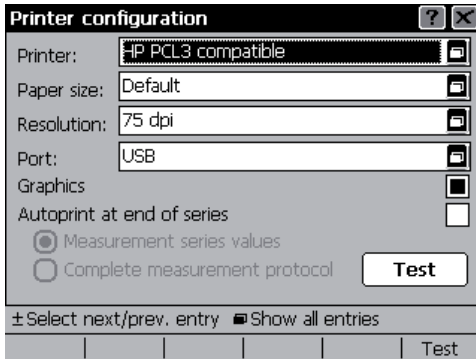

- ▶ Select type of connected printer in "Printer" (see p. 38).
 - ▶ Select paper size in "Paper size".
 - ▶ Select printer resolution in "Resolution".
 - ▶ Select port (Serial or USB) to which the printer is connected in "Port".
- If a bar graph is to be printed:

- ▶ Check the "Graphics" checkbox.

If a protocol is to be printed at the end of each measurement series:

- ▶ Check the "Autoprint at end of series" checkbox and select short or complete protocol.

- ▶ In order to test the settings, click the "Test" button or press the  key.

↪ A test page is printed.

4.8.2 Printing protocols

If "Autoprint at end of series" has been enabled, the indicating device will automatically print a protocol every time a measurement series is closed. The protocol type (short, long with or without diagram) is selected in the "Printer configuration".

To disable automatic printing:

- ▶ Open the "Printer configuration" dialog box as described in the previous section.
- ▶ Uncheck the "Autoprint at end of series" checkbox.

In addition, a protocol of the currently displayed series can be printed at any time:

- ▶ Select menu item "Measurement".
- ▶ Select submenu item "Print series".
- ▶ Select submenu item "Long protocol" or "Short protocol".
- ↳ Depending on the selection a long or a short protocol of the currently displayed measurement series is printed.

4.8.3 Description of protocol printouts

Short protocol

Top row:	Lo	Lower tolerance limit
	Hi	Upper tolerance limit
	D&T	Date and time of measurement

Table of individual readings, listing the current number, the measured hardness on the native scale of the impact device (e.g. HLD) and on the converted scale and the impact direction setting.

Bottom row:	Min	Lowest measured value of the series
	Max	Highest measured value of the series
	Ave	Sample mean of the series
	s	Sample standard deviation of the series

Long protocol

Equipment

Instrument:		Type of indicating device (EQUOTIP3)
Instrument serial number:		Serial number of indicating device
Probe:		Type of impact device
Probe serial number:		Serial number of impact device

Settings

Lower limit:	Lo	Lower tolerance limit (if set)
Upper limit:	Hi	Upper tolerance limit (if set)
Material group:		Selected material group
Hardness scale:		Selected hardness scale

Series

File name:		Series file name
Date:		Date of measurement
Time:		Time of measurement

Readings

Table of individual readings, listing the current number, the measured hardness on the native scale of the impact device (e.g. HLD) and on the converted scale and the impact direction setting.

Statistics

No. of readings:	<i>N</i>	Number of readings
Mean value:	<i>Ave</i>	Sample mean of the series
Min value:	<i>Min</i>	Lowest measured value of the series
Max value:	<i>Max</i>	Highest measured value of the series
Span:	<i>R</i>	Sample span of the series (see next section) - absolute - relative to mean value in parenthesis
Standard deviation:	<i>s</i>	Standard deviation of the series (see next section) - absolute - relative to mean value in parenthesis

Mean error:	δ	Uncertainty of the sample mean (see next section) - absolute - relative to mean value in parenthesis
Process capability:	C_p	C_p process capability coefficient (see next section), only if both upper and lower tolerance limit are set - sample process capability C_p - lower confidence limit in parenthesis
Process capability:	C_{pk}	C_{pk} process capability coefficient (see next section), only if at least one tolerance limit is set - sample process capability C_{pk} - lower confidence limit in parenthesis

4.8.4 Remarks on the statistics of measurement series

This chapter is relevant for advanced users only.

Given is a series of N measured values (x_1, x_2, \dots, x_N) . The individual readings x_i are supposed to be the sum of the true value ξ of a repeatedly measured physical quantity and random measurement errors ε_i .

$$x_i = \xi + \varepsilon_i$$

Distribution parameter estimates

The arithmetic mean of the N readings x_i ,

$$\bar{x} = \frac{1}{N} \sum_{i=1}^N x_i$$

is called the *sample mean*, which is the most natural estimate of the true value ξ . Denoting the smallest and the largest measured value by

$$x_{\min} = \min_{1 \leq i \leq N} \{x_i\} \quad \text{and} \quad x_{\max} = \max_{1 \leq i \leq N} \{x_i\}$$

respectively, a simple measure of the data *scatter* is given by the *sample span* $R = x_{\max} - x_{\min}$

The problem with these R values is, that they generally increase with the sample size N , and hence they are only meaningful distribution scatter indicators for a fixed sample size.

The sample *standard deviation*

$$s = \sqrt{\frac{1}{N-1} \sum_{i=1}^N (x_i - \bar{x})^2} \quad (N \geq 2)$$

however, is a sample size independent statistical measure of the scatter of data.

In the language of statistics: If the measured values are samples of a normal distributed random process with mean value μ and variance σ^2 , having the well known bell-shaped probability density function

$$\varphi(x) = \frac{1}{\sigma\sqrt{2\pi}} e^{-\frac{1}{2}\left(\frac{x-\mu}{\sigma}\right)^2}$$

then \bar{x} is the most efficient unbiased estimator for the distribution mean μ and s^2 is an unbiased estimator for the distribution variance σ^2 (but s is *not* an *unbiased* estimator for the distribution standard deviation σ !).

In the absence of systematic errors, $\xi = \mu$.

Uncertainty of the sample mean

With measurement series it is normally not important to estimate the parameters of underlying probability distribution (μ and σ^2 in case of a normal distribution). A more interesting question to answer is, how much the sample mean is expected to deviate from the true mean μ .

Provided the underlying distribution is normal, the probability that the distribution mean and the sample mean differ in magnitude by more than

$$\delta = t_{\alpha/2, N-1} \frac{s}{\sqrt{N}}, \quad N \geq 2$$

is less than α . α is called *significance level* and is conventionally chosen to be 0.05 (= 5 %). $1-\alpha$ is called the *confidence level*. The factor $t_{\alpha/2, N-1}$ is a quantile of the t distribution with $N-1$ degrees of freedom. No closed formula is known to calculate t-distribution quantiles as a function of α and N .

Approximate values for $\alpha=0.05$ and some sample sizes N are given in the table below:

N	$t_{0.025,N-1}$	$\chi^2_{0.05,N-1}$	N	$t_{0.025,N-1}$	$\chi^2_{0.05,N-1}$
2	12.706	3.841	11	2.228	18.307
3	4.303	5.991	12	2.201	19.675
4	3.182	7.815	13	2.179	21.026
5	2.776	9.488	14	2.160	22.362
6	2.571	11.070	15	2.145	23.685
7	2.447	12.592	20	2.093	30.144
8	2.365	14.067	25	2.064	36.415
9	2.306	15.507	30	2.045	42.557
10	2.262	16.919	∞	1.960	

Example: $N = 5$, $\bar{X} = 514.2$, $s = 2.14$, then $\delta = 2.776 \cdot 2.14 / \sqrt{5} \approx 2.66$.

So there is a 95 % probability that the true distribution mean is in the range 514.2 ± 2.66 , that is between 510.54 and 516.86.

Process capabilities

Different questions may arise if tolerance limits are specified. Assume that the measured quantity scatters over a certain range, e.g. hardness values on an inhomogeneous surface. Hardness is measured at a few random locations. How sure can one be that hardness is in tolerance at *any* point of the surface? And: Is the data scatter small enough so that the distribution "fits conveniently" into the tolerance band?

Note that we assume here, that data scatter is not caused by random measurement errors of a constant quantity but by scatter of the measured quantity itself!

A statistical answer to the second question is provided by the *sample process capability coefficient* C_p . Let L denote the lower and U the upper limit,

$$C_p = \frac{U - L}{6s}$$

In other words: C_p is the tolerance band width in units of six times the estimated standard deviation. A process is conventionally considered *capable*, if C_p is greater than unity. - If either L or U is not specified, or if $N=1$, C_p is not defined.

The *sample process capability coefficient* C_{pk} is defined by

$$C_{pk} = \min \left\{ \frac{\bar{x} - L}{3s}, \frac{U - \bar{x}}{3s} \right\}$$

if both the lower and upper tolerance limit is specified. If only a lower limit L or only an upper limit U is set, C_{pk} is defined by

$$C_{pk} = \frac{\bar{x} - L}{3s} \quad \text{or} \quad C_{pk} = \frac{U - \bar{x}}{3s}$$

respectively. When neither L nor U is given, or if $N=1$, C_{pk} cannot be calculated.

C_{pk} may answer the first of the above questions, which is normally the more interesting one. Assuming for a moment that s is a very good estimate of the true standard deviation, $C_{pk} \geq 1$ indicates that more than 99.7 %, of the individual measurements of (hypothetical) very large series are expected to be in tolerance, provided the underlying distribution is normal.

Unfortunately, with small measurement series we cannot be sure that s is a good estimate of σ . Taking series of N measurements of the same quantity repeatedly will typically yield a sequence of sample standard deviations which scatter over a relatively wide range. Consequently the sample process capabilities will scatter heavily, too. Thus lower *confidence limits* for the process capabilities are desirable.

If C_p^* and C_{pk}^* denote the distribution process capabilities, one tries to estimate numbers $C_{p,lower}$ and $C_{pk,lower}$ from the data, such that the probabilities for $C_p^* \geq C_{p,lower}$ and $C_{pk}^* \geq C_{pk,lower}$ are greater than the prescribed confidence level $1-\alpha$.

$$C_{p,lower} = C_p / \sqrt{\frac{\chi^2_{\alpha, N-1}}{N-1}}$$

$$C_{pk,lower} \approx C_{pk} - z_{1-\alpha} \sqrt{\frac{1}{9N} + \frac{C_{pk}^2}{2(N-1)}}$$

where $\chi^2_{\alpha, N-1}$ is a quantile of the chi-square distribution with $N-1$ degrees of freedom and $z_{1-\alpha}$ is a quantile of the normal distribution. For the 5 % standard significance level, $\chi^2_{0.05, N-1}$ values are given in the table above and $z_{0.95} = 1.645$.

Example: $N = 5$, $\bar{x} = 514.2$, $s = 2.14$; $L = 500$, $U = 550$.

$C_{pk} = 14.2 / (3 \cdot 2.14) = 2.212$.

$C_{pk,lower} = 2.212 - 1.645 \cdot \sqrt{(1/45 - 2.212^2/8)} = 0.902$.

Conclusion: Although the sample C_{pk} is greater than 2, the probability that the distribution C_{pk}^* is less than one is greater than 5 %.

If $N = 10$ in the above example, $C_{pk,lower} = 1.337$ and the error probability is less than 5 %.

Final remarks

Probability theory and statistics are mathematical methods, which can be used to construct idealized models of real-world situations. The results, though formally exact, are only as good as the model corresponds to reality. The methods presented here do not take into consideration

- Systematic errors
- Data discretisation
- Underlying distribution is not normal
- Outliers (often, but not always caused by handling errors)
- Intentional data manipulation

and many more effects, of which we hope that they are negligible

More information:

Engineering Statistics Handbook, www.nist.gov/stat.handbook

4.9 Memory management

The EQUOTIP® 3 explorer is used to open and show saved measurement series, to delete, rename, move and print measurement series and to organise and manage them into folder structures.

- ▶ Select menu item "Memory".
- ▶ Select submenu item "Explorer...".
- ↳ The file explorer opens:

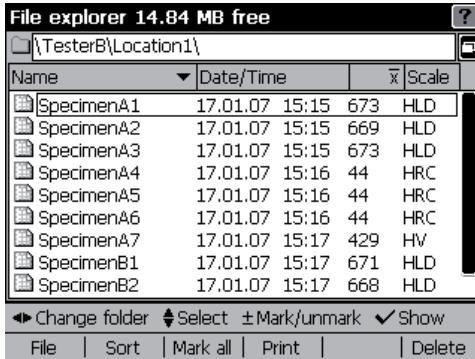

Navigation



Changing folders:

- ▶ Select required folder with up / down arrow keys.
- ▶ Enter folder with right arrow key.
- ▶ Return to upper folder with left arrow key.

Marking files / folders:





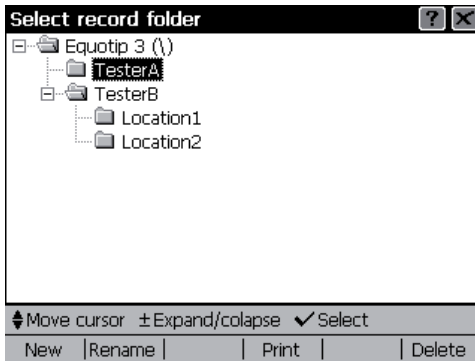

- ▶ Select required file / folder with up / down arrow keys.
 - ▶ Mark / unmark the selected file / folder by pressing the "+" or "-" key
- or:
- ▶ Mark / unmark all files / folders for group operations (i.e. move, delete) by pressing the  key.

Showing the content of files / folders:

- ▶ Select required file/folder with up / down arrow keys.
- ▶ Open it by pressing the  key.
- ▶ Show the previous / next file by pressing the "+" or "-" key.
- ▶ Close the file by pressing the  key.

Directory structure







- ▶ Press the  key to open the folder tree.
- ▶ Select folders with the up / down arrow keys.
- ▶ Expand / collapse subtrees with the "+" or "-" key.
- ▶ Enter a selected folder with the  key.
- ▶ Create a new folder with the  key.
- ▶ Rename existing folders with the  key.
- ▶ Print the folder organization tree directly to an attached printer with the  key.
- ▶ Delete a selected folder with the  key.

Functions

- "File" ( key): Possibility to create a new folder and to rename, move, cut, paste, delete or undelete files and folders:
 - "New folder": opens a Keyboard for inputting a new folder name.
 - "Rename": opens a Keyboard for changing the name of the marked file / folder.
 - "Move": opens the folder tree to select folder to which marked files / folders are to be moved to.
 - "Cut": greyed out marked files / folders and writes them into the working memory.
 - "Paste": moves files / folders from the working memory into the current folder.
 - "Delete": deletes marked files / folders.
 - "Undelete": deletion of files / folders is undone.

NOTE: Only the last deletion can be undone with "Undelete".

- "Sort" ( key): Possibility to change the order in which the data is displayed in the explorer. All files and folders in the current directory can be sorted by name, date, value and scale (everything in reverse also).
- "Mark all" ( key): Possibility to mark / unmark all files and folders in the current directory.
- "Print" ( key): Possibility to print a long or short protocol of the selected files / folders. Also the file and folder structure can be printed as well with the files and folders inside the selected folders.
- "Delete" ( key): Possibility to delete the selected files / folders.



4.10 User configurations / profiles

4.10.1 User interface

The interface preferences can be configured independently for each individual user.

- ▶ Select menu item "Config".
- ▶ Select submenu item "User interface...".

It is possible to select Keyboard or SMS style as for text input.



- ▶ Use the  key to expand all the choices and select with the arrow keys.
- ▶ Confirm selection by pressing the  key.

With activating check boxes, the individual features can be enabled (see p. 37):

- "Scroll long filenames" will allow the entire file name to scroll across the screen if it is too long to be displayed all at once.
- "Scroll to see active user profile" will rotate the time and date display with the active user profile every 6 seconds.
- "Show navigation help bar" enables the on screen active key hints to be displayed.
- "Show status bar" displays the measurement setup (impact direction, impact device, conversion etc).
- "Show global status bar (on top)" displays the time & date and connection icons at the top of the display.
- "Show warning when changing material / scale" display an information box when the material or scale are to be changed.





4.10.2 User profiles

Changing active user profile

- ▶ Select menu item "Config".
- ▶ Select submenu item "User profiles ▶".
- ▶ Select submenu item "Change user...".
- ▶ Use the  key to expand all the choices and select with the arrow keys.
- [su] means "super user", who is a user that can edit other user files.
There must always be at least 1 super user profile present.
- [*] identifies the current active user.
- ▶ Confirm selection by pressing the  key.
- ↳ New user profile is active.

A login screen will appear upon exit (pressing  key) if a password is enabled for the selected user (see p. 76).

Creating a new user profile

- ▶ Select menu item "Config".
- ▶ Select submenu item "User profiles ▶".
- ▶ Select submenu item "User profiles...".
- ▶ Select button "New".
- ▶ Confirm by pressing the  key.
- ▶ Enter a name for the profile.
- ▶ Close the "Name new profile" dialog box with the  key.
- ▶ Assign access rights to the new profile (see p. 76).
- ▶ Close the "Access rights" dialog box with the  key.
- ▶ Select button "Yes".
- ↳ A new user profile is created and saved.
- ▶ Close the "User profiles management" dialog box with the  key.
- ▶ To activate the new user profile: see previous section "Changing active user profile".



NOTE

User profile settings

The device settings (see p. 23 and the following) are saved automatically for the active user profile. When creating a new user profile or editing an existing one, the access rights are not set automatically but must be assigned by a super user [su] (as shown in the title bar of the access rights dialog box: [x -> y]).

Access rights

The EQUOTIP® 3 provides the possibility to assign access rights to the individual user profiles.

- ▶ Select menu item "Config".
- ▶ Select submenu item "User Profiles ▶".
- ▶ Select submenu item "Access rights..."

or

- ▶ Select menu item "Config".
- ▶ Select submenu item "User Profiles ▶".
- ▶ Select submenu item "User Profiles".
- ▶ Select button "Edit".

The Access rights dialog has 8 tabs that contain selections organized by category. These rights can be used to limit access to features and settings for each individual user.

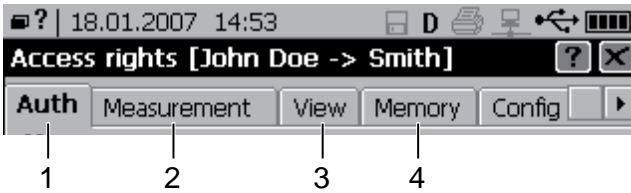

Description of the tabs

1. Tab "Auth" (basic authorisations)	
Checkbox	Description
"Access rights"	Allows or denies access to the access rights dialog (this menu item) for the selected user NOTE: Users can block themselves from this menu if the feature is disabled!
"Change password"	Enables or disables the ability of the user to change their password
"Login prompt at startup"	Enables or disables the login screen at power-up for the selected user
"Authenticate for access rights dialog"	To access the "Access rights" dialog the user must enter a password (if one was defined before)

2. Tab "Measurement" (features of the measurement menu)	
Checkbox	Description
"Direction"	Ability to change the impact direction
"Scale"	Ability to change the displayed hardness scale
"n"	Permits or denies the ability of the user to change the number of measurements in a series
"Close / more"	Enables or disables the ability of the user to manually open and close measurement series before the defined "n" has been reached
"Delete"	Permits or denies the ability of the user to delete individual readings
"Comment"	Enables or disables the ability of the user to add a comment to a measurement or series
"Limits"	Permits or denies the ability of the user to modify the settings of the limits in the measurement mode

2. Tab "Measurement" (features of the measurement menu)

Checkbox	Description
"Print long protocol" "Print short protocol" "Print screenshot"	Enables or disables the user access to print data according to the named protocol
"New"	Permits or denies the "New" functionality

3. Tab "View" (features of the view menu)

Checkbox	Description
"Bar graph"	Controls user access to the bar graph view
"Signal graph"	Controls user access to the signal graph view
"Conversion curve"	Controls user access to the conversion curve view
"Basic mode"	Controls user access to the basic mode view
"Display mean"	Blocks the user from changing the current setting for displaying mean values
"Set bar graph range"	Blocks the user from changing the current setting for the vertical display range of the bar graph in "Bar graph view"
"Multiple series bar graph"	Blocks the user from changing the current setting for displaying series data in the bar graph (single or multiple series)
"Scale bar width"	Blocks the user from changing the current setting for the bar width in the bar graph display

4. Tab "Memory" (features of data storage)

Checkbox	Description
"Change record"	Blocks the user from changing the setting for automatic save at the end of a measurement series (disk button)
"Set save folder"	Blocks the user from modifying the selected folder for storing data
"Rename"	Permits or denies the user from being able to rename a file or folder
"Explorer"	Controls user access to the Explorer feature for data review and management
"Info"	Controls user access to view the memory properties summary information

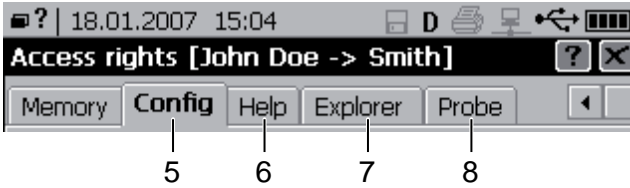

5. Tab "Config" (device configuration settings)	
Checkbox	Description
"Printer"	Controls user access to view and change printer settings
"Language"	Controls user access to view and change language settings
"User interface"	Controls user access to view and change user interface
"Date / time"	Controls user access to view and change the date, time and format of the display for date and time
"Display"	Controls user access to view and change display settings (contrast and backlight)
"IP settings"	Controls user access to view and change the settings for the Ethernet connection
"Power manager"	Controls user access to view and change the settings for time to idle and time to standby power modes
"Sound"	Controls user access to view and change the audible signals for system events
"Signal compression"	Controls user access to view and change the settings for how the EQUOTIP® 3 handles the raw signal (save or do not save the signal, signal compression)
"Customer conv."	Controls user access to view, create and change the customer specific conversion curves stored in the EQUOTIP® 3
"Calibrate probe"	Controls user access to view and change the calibration for an EQUOTIP® impact device

6. Tab "Help" (access to help menu items)

Checkbox	Description
"About EQUOTIP3"	Controls user access to view the EQUOTIP® 3 hardware and firmware information
"Show help index"	Controls user access to view the index of the EQUOTIP® 3 online help
"Show help content"	Controls user access to view the contents of the EQUOTIP® 3 help files
"Direct Help (?)"	Blocks or allows the use of the  button to display the context sensitive help files

7. Tab "Explorer" (access to file features of EQUOTIP® 3 Explorer)

Checkbox	Description
"New folder"	Controls user access to create data storage folders
"Rename"	Controls user access to rename data storage folders
"Move / cut / paste"	Controls user access to move folders around within EQUOTIP® 3 Explorer
"Delete / undelete"	Controls user access to delete and restore folders
"Sort"	Controls user access to change the order in which the data is displayed in EQUOTIP® 3 Explorer
"Mark / mark all"	Controls user access to mark files and folders for group operations (i.e. move, delete)
"Print folder tree"	Controls user access to print the folder organization tree directly to an attached printer
"Change folder"	Controls user access to change the currently set save folder for data storage

8. Tab "Probe" (access to use of different probes)



Checkbox	Description
"Allow all probes" "Only allow this probe:"	Controls user ability to use different impact devices with the EQUOTIP® 3. Can be set to allow all impact devices, or restrict the use to just one type (i.e. D, E, G, C, DL)

4.11 Help system



The error messages that are displayed by the EQUOTIP® 3 are in plain text. The EQUOTIP® 3 also provides a comprehensive online help system to explain error messages and operation of the instrument.

Opening the help system

Option 1

- ▶ Press the  key to open the context sensitive help page.
This means that the help topic for the current active display screen (or menu feature) will be displayed.
- ▶ Navigate with the arrow keys through the help page.
- ▶ Close the dialog with the  key.

Option 2

- ▶ Press the  key.
- ▶ Select the menu item "Help".
- ▶ Select the submenu item "Show help index...?" to open the index.
- ▶ Close the dialog with the  key

or

- ▶ Select the submenu item "Show help content...?" to open the help manual.

5 EQUOLINK3 evaluation software

5.1 Description and properties

EQUOTIP® 3 is supplied with its own application software EQUOLINK3 for communication with a PC via Ethernet or USB interface.

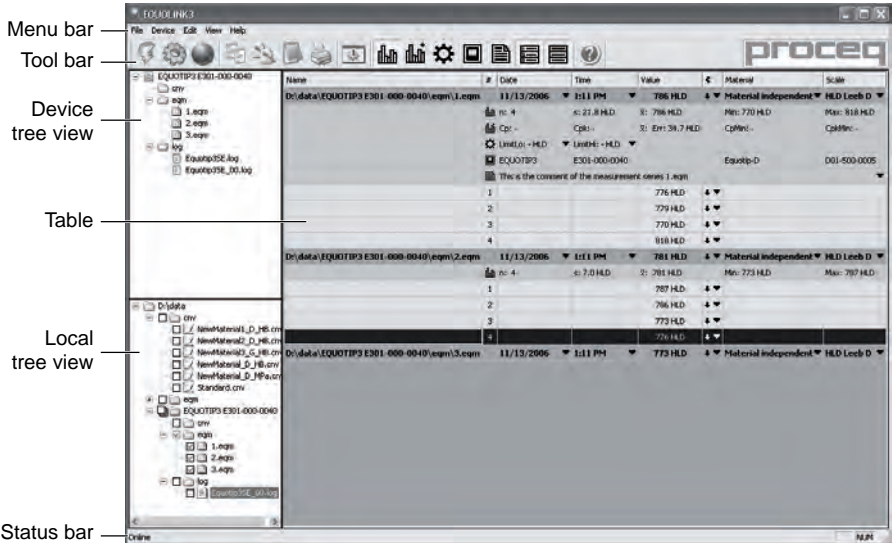

Fig. 5.01 EQUOLINK3

The software has the following features:

- Connect the EQUOTIP® 3 to the PC
- Simple download by drag & drop
- Download of measurement series, conversions and log files from the EQUOTIP® 3
- Local file management in tree view
- Show and edit measurement series in the table
- Change, print and export of measurement series
- Upgrade the EQUOTIP® 3 firmware

5.2 Installing EQUOLINK3

System requirements

- Windows 2000 / Windows XP
- USB connection
- Min. 5 MB free disk space

NOTE

The EQUOLINK3 software and the USB driver must be installed before the EQUOTIP® 3 can be connected via USB to the computer.

- ▶ Switch ON the PC.
- ▶ Connect the supplied USB memory stick to the USB interface of the PC.
- ▶ Open the memory stick drive folder and launch the "EQUOLINK3_Setup_V_1_0_0.exe" file.
- ↳ The following dialog box is displayed:

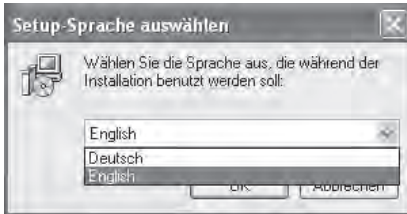

- ▶ Select the language.
- ▶ Click "OK".

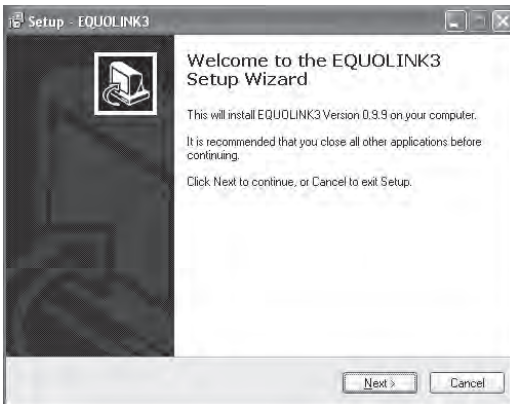

- ▶ Click "Next >".

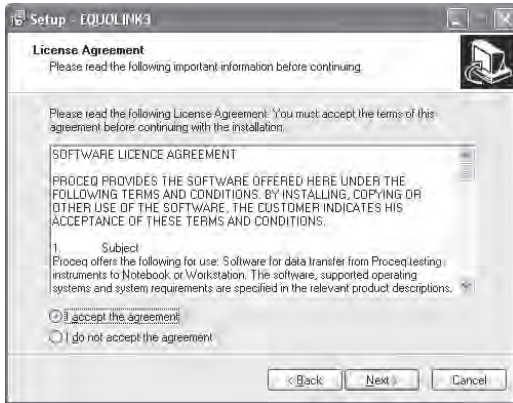

- ▶ Read the license agreement.

If you accept all the conditions:

- ▶ Select "I accept the agreement".
- ▶ Click "Next >".

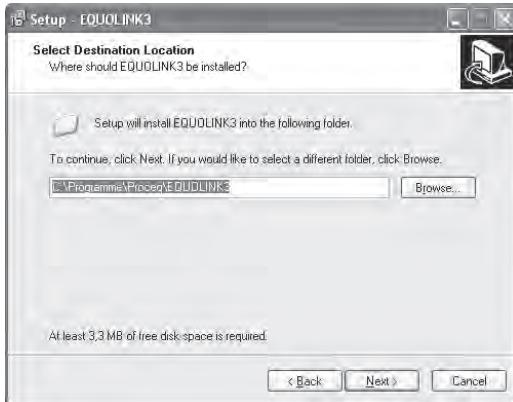

- ▶ Select the destination folder for the installation.
- ▶ Click "Next >".

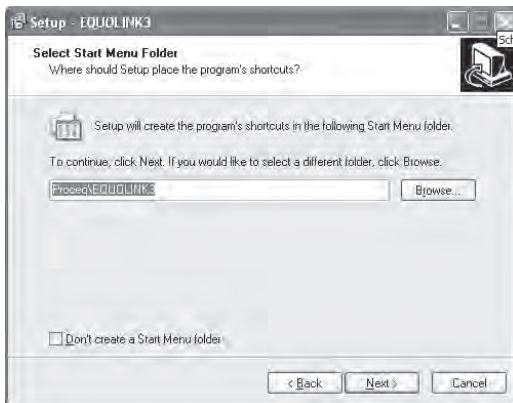

If necessary:

- ▶ Select the folder in the start menu.
- ▶ Click "Next >".

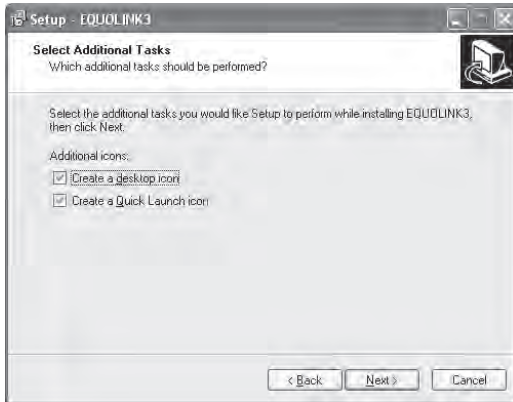

If necessary:

- ▶ Select additional icons.
- ▶ Click "Next >".

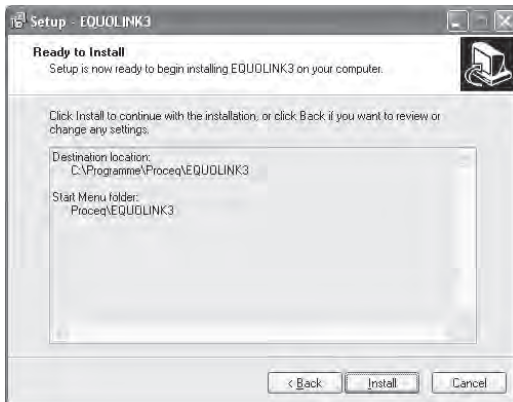

- ▶ Check the settings.
- ▶ Click "Install".



- ▶ Click "Finish".
- ↪ The installation is complete.

5.3 First connection between EQUOTIP[®] 3 and the PC

Installation of the USB driver

The USB driver establishes the communication between the device and the PC software via a USB interface.

Normally, the driver is installed automatically with installing the EQUOLINK3 software (see previous section).

If not: the operating system of the PC prompts the user to install the corresponding driver for it when the EQUOTIP[®] 3 device is connected to the host PC for the first time.

- ▶ Switch ON EQUOTIP[®] 3.
- ▶ Connect the indicating device to operational PC with USB cable (see p. 19).
- ↳ Windows will find a new piece of hardware connected, and the "Found New Hardware Wizard" will launch:



- ▶ Select "No, not this time".
- ▶ Click "Next >".

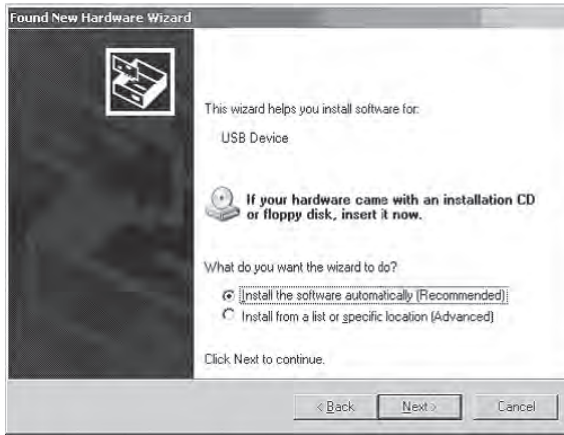

- ▶ Select "Install the software automatically (Recommended)".
- ▶ Click "Next >".

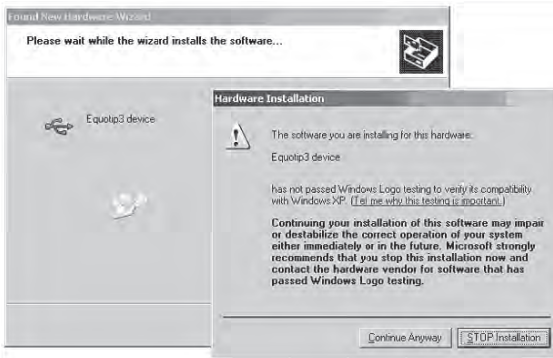

- ▶ Click "Continue Anyway".
- ↪ The device is now installed and ready to use.

5.4 Working with EQUOLINK3

Connecting

- ▶ Connect indicating device to operational PC with USB or Ethernet cable (see p. 19).
- ▶ Start application EQUOLINK3.
- ▶ Select the "Device" menu from the menu bar, select "Connect device" in the submenu

or

- ▶ Click the  symbol in the tool bar.

↳ The following dialog opens:

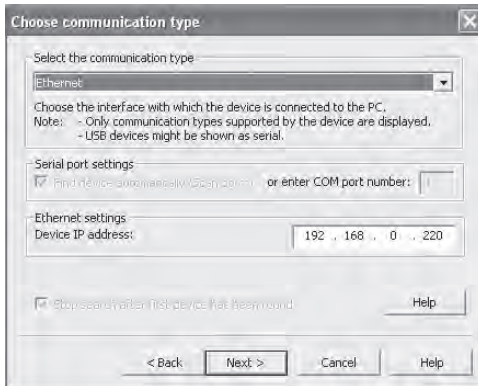

- ▶ Select the communication type.

If Ethernet is selected:

- ▶ Enter the IP address of the device.
- ▶ Click "Next >".

↪ The following dialog opens:

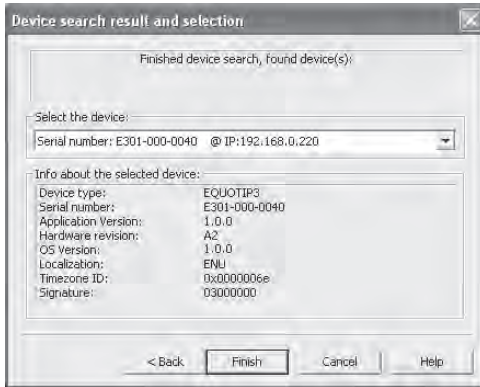

↪ The device is found.

↪ Information about the device are displayed.

▶ Click "Finish".

↪ The folder tree of the device is shown in the tree view.

↪ On the indicating device display the following screen is shown:

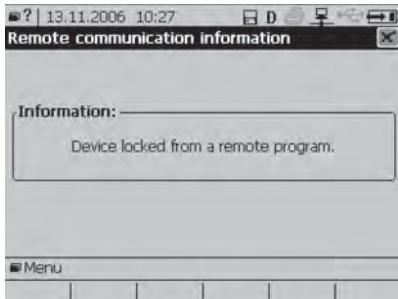



NOTE

Connection problems using EQUOLINK3

- ▶ Select the "Help" menu from the menu bar.
 - ▶ Select "EQUOLINK3 Help" in the submenu or click the  symbol in the toolbar.
- ↵ The online help opens.

5.4.1 Tool bar



- 1 Connect PC to device
- 2 Change device settings
- 3 Start PqUpgrade (OS and application upgrade)
- 4 Copy selected table content as text
- 5 Copy selected table content as picture
- 6 Export table content as txt format
- 7 Print table content
- 8 Change application settings
- 9 Show / hide statistics of the selected measurement series
- 10 Show / hide extended statistics of the selected measurement series
- 11 Show / hide device settings of the selected measurement series
- 12 Show / hide device information of the selected measurement series
- 13 Show / hide comment of the selected measurement series
- 14 Show / hide single values of the selected measurement series
- 15 Show / hide background color in the table of the selected measurement series
- 16 Open help file of the EQUOLINK3 application

5.4.2 Application settings

▶ Select menu item "File" and submenu item "Application settings" from the menu bar

or:

▶ Select  from the tool bar.

↳ The following dialog opens:

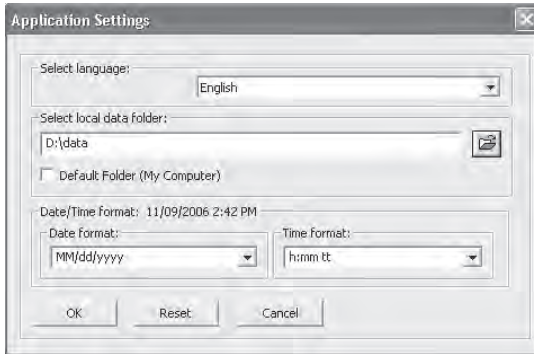

Several settings can be made:

– First list box: language is selectable.

– Input field: path of local data folder (local or server) can be selected.
Activate checkbox to set the local folder "My Computer" as default folder.

– Second and third list boxes: Format for date and time can be set.

▶ Click "OK" to confirm settings

or:

▶ Click "Reset" to restore the default settings

or:

▶ Click "Cancel" to discard changes.

5.4.3 Views

Device tree view

The data of the connected indicating device is displayed in the upper folder tree:

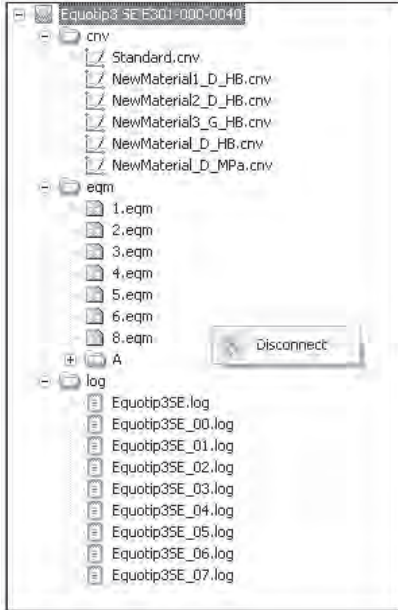

Folders

- "cnv" folder:
conversion files stored in the device
- "eqm" folder:
measurement series files stored in the device
- "log" folder:
log files stored in the device

Context menu

- "Disconnect" the connection between indicating device and PC

Local tree view

The data of the local PC is displayed in the lower folder tree. Data can be copied from device to PC by "drag and drop".

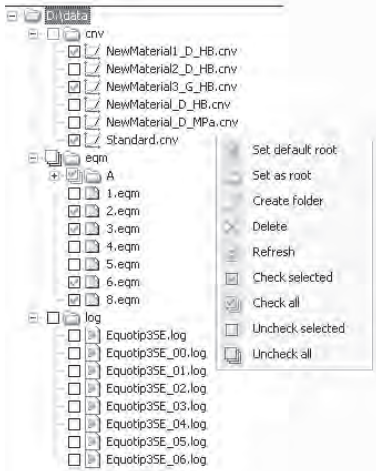

Folders

- "cnv" folder: the checked conversion files are loaded and can be selected as "customer defined" material
- "eqm" folder: the checked measurement series files are displayed in the table
- "log" folder: the checked log files can be opened in an external text editor

Context menu

- "Set default root": set default folder ("My Computer")
- "Set as root": selected folder is set as root
- "Create folder": new folders can be created
- "Delete" folders or files (also by pressing "DEL" key)
- "Refresh": update folder tree
- "Check selected": activate checkbox (eqm file is shown in the table)
- "Check all": activate all checkboxes (all eqm files are shown in the table)
- "Uncheck selected": deactivate checkbox
- "Uncheck all": deactivate all checkboxes

5.4.4 Table features

Edit fields

Table fields with an arrow  can be edited.

With mouse:

- ▶ Click on the field to select it.
- ↶ Selected field will be highlighted with a white outline.
- ▶ Click again to edit the field.
- ▶ Click outside the edited field to save changes.

With PC keyboard:

- ▶ Select the field by using the cursor keys.
- ▶ Press "SPACE" to edit the field.
- ▶ Press "ENTER" or "ESC" to save changes.

Show details

- ▶ Double-click in name field of a measurement series to expand / collapse the view and show detailed information.

Change date / time

- ▶ Double-click in date field.
 - ↪ The field becomes editable.
 - ▶ Change date with arrow buttons
- or:
- ▶ Double-click in time field.
 - ↪ The field becomes editable.
 - ▶ Change time with arrow buttons.



- ▶ Click outside the field or press "ENTER" to confirm changes.

Change impact direction

- ▶ Double-click in impact direction field.
 - ↪ Context menu opens.
- ▶ Select required impact direction.



Change material / scale

- ▶ Double-click in material or scale field.
- ↳ Context menu opens.
- ▶ Select required material and scale.

Material	Scale			
1 Steel and cast steel	HLD	Leeb D	(0 ... 999 HLD)	
2 Work tool steel	HB	Brinell	(81 ... 654 HB)	
3 Stainless steel	HV	Vickers	(81 ... 955 HV)	
4 Gray cast iron (GG)	HRB	Rockwell B	(38 ... 100 HRB)	
5 Nodular cast iron (GGG)	HRC	Rockwell C	(20 ... 68 HRC)	
6 Cast aluminium alloys	HS	Shore	(30 ... 99 HS)	
7 Brass	MPa	Tensile strength		
8 Bronze	HLS	Leeb S	(374 ... 962 HLS)	
9 Wrought copper alloys	HLE	Leeb E	(295 ... 918 HLE)	
Customer defined	HLDL	Leeb DL	(562 ... 987 HLDL)	

Change Limits

- ▶ Select  from the tool bar to display the device settings in the table.
- ▶ Double-click in settings field to change device settings.

	LimitLo: 400 HLD	LimitHi: 600 HLD
	LimitLo: 400 HLD	LimitHi: 600 HLD

- ▶ Click outside the field or press "ENTER" to confirm settings.

Mark table rows

To select several rows:

- ▶ Drag the cursor over the rows while pressing the left mouse button or:
- ▶ Click on several rows while pressing the "CTRL" key or:
- ▶ Select several rows with "SHIFT" and "Cursor UP" or "DOWN" keys.

Context menu

A context menu is available in the table by clicking the right mouse key. It provides several functions:

- "Conversion": New material and hardness scale can be set:



- "Impact direction": Impact direction can be changed:

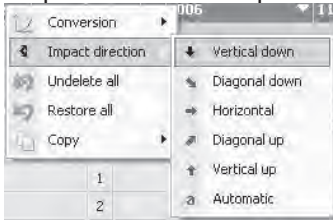

- "Undelete all": Deleted single values are restored
- "Restore all": All changes are restored
- "Copy": Selected data is copied as text or as picture to clipboard

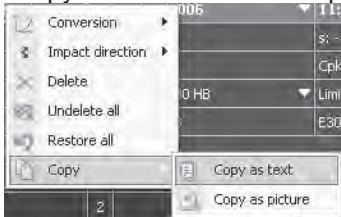

Export

EQUOLINK3 provides an export interface to external common software. Measurement series data can be exported to a standard text file (.txt) optimized for MS EXCEL.

▶ Select file in the menu bar and export in the submenu bar

or:

▶ Select  from the tool bar.

↪ The export file dialog opens.

▶ Select destination folder and click "Export".

↪ All opened measurement series are exported in a txt-format.

Print

EQUOLINK3 provides the possibility to print measurement data:

▶ Select file in the menu bar and print in the submenu bar

or:

▶ Select  in the tool bar.

It is possible to print all data or just the data rows that are marked.



CAUTION

Disconnection of the data connection

Data transfer is interrupted.

▶ Do not disconnect the unit from the PC during data transfer.

If the data transfer is interrupted:

↪ Re-establish connection.

5.5 Software upgrade

The express update is the easiest and recommended way to upgrade the firmware of the EQUOTIP® 3 device. The PqUpgrade software will automatically load the latest version of the firmware.



NOTE

Communication type

Recommended is an upgrade via TCP/IP or USB; the RS232 interface is not suitable due to its low speed.



NOTE

Slow system performance

When an upgrade is carried out, sectors of the indicating device memory are deleted and others created. That could result in a slow device system performance for some minutes.

5.5.1 Application upgrade

- ▶ Connect the PC to the internet.
The PC must be connected to the internet during the upgrade because the upgrade files will be loaded from the Proceq FTP server.
- ▶ Connect the indicating device to the TCP/IP network **or** via USB cable to the PC (see p. 19).
- ▶ If the connection is established via USB: Ensure that the USB driver is installed on the PC (see p. 86).
- ▶ Switch the device power ON.
- ▶ Ensure that device is mains-powered or has an almost full battery.
- ▶ Ensure that the active device profile is a "super user [su]" (see p. 75) and authenticate to do an upgrade (if a password is defined).

- ▶ Start application EQUOLINK3 on the PC.
 - ▶ Select menu item "Device" and submenu item "PqUpgrade"
- or
- ▶ Click the  symbol in the tool bar.
- ↳ The following dialog opens:

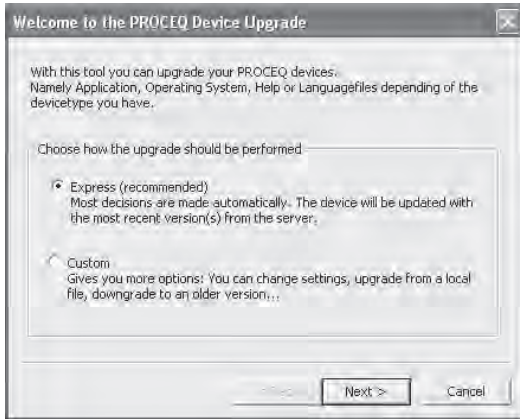

- ▶ Select "Express (recommended)".
- ▶ Click "Next >".

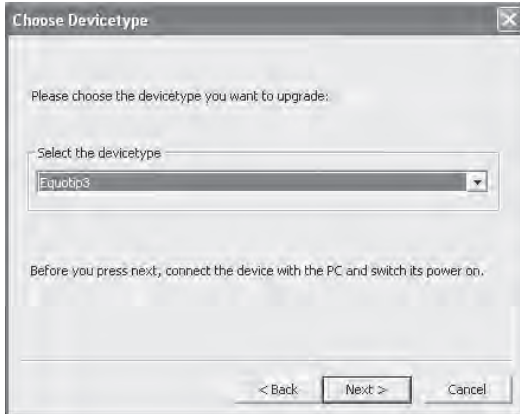

- ▶ Select "Equotip3".
- ▶ Click "Next >".

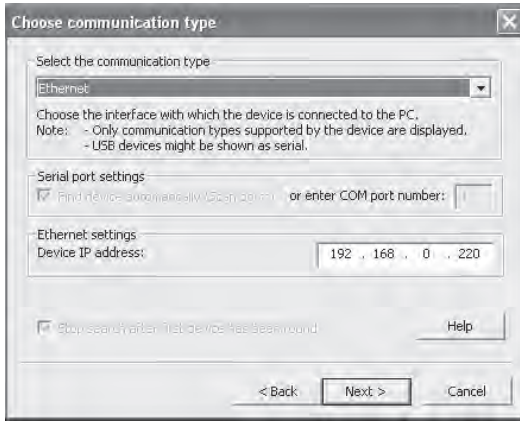

▶ Select communication type.

If "Ethernet" is selected:

▶ Enter the IP address of the device.

If the IP address is unknown:

▶ Select menu item "Config", select submenu item "System settings", select "IP settings".

↖ The current IP address will be displayed in the top bar of the IP settings dialog box.

▶ Click "Next >".

↖ The device is found in the network.

↖ Information about the device to be upgraded is displayed.

▶ Click "Next >".

If the connection between PC and device cannot be established or no device information is displayed:

▶ Check IP settings, Ethernet cable or USB cable.

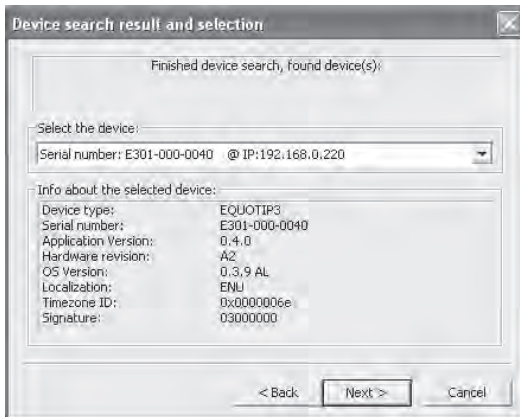

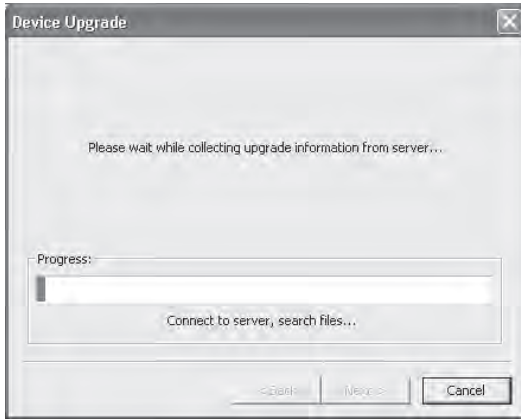

↖ The connection to the Proceq FTP server is established.

↖ The Proceq server is scanned for available upgrades.

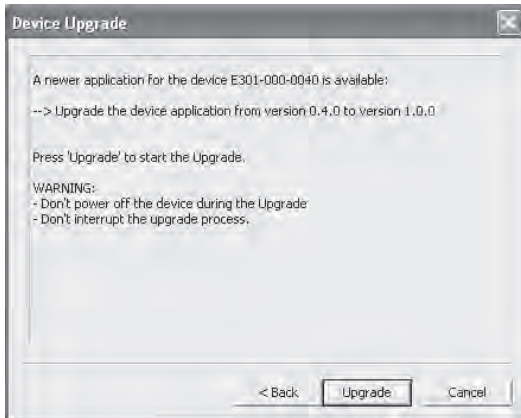

↖ PqUpgrade has found a newer application version.

▶ Click "Upgrade" to start the application upgrade.

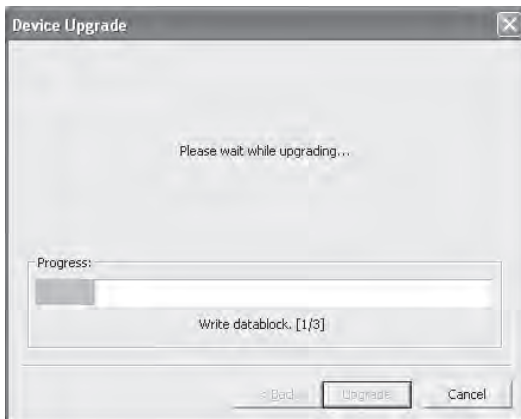

↖ The device upgrade is being carried out.

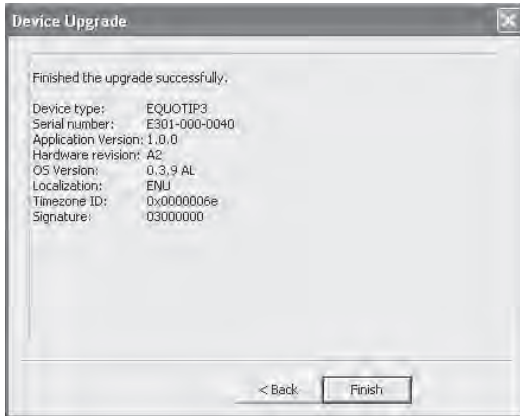

↖ The installation of the new application software upgrade could take some minutes.

When the installation is complete:

- ▶ Click "Finish".
- ▶ Restart the device.

5.5.2 Operating system upgrade

To upgrade the device operating system, follow the same procedure as described before in "5.5.1 Application upgrade".

5.5.3 Custom upgrade

The upgrade in "Custom" mode provides more options, but it is recommended for advanced users only. Please refer to the help files of the PqUpgrade software for more details.

5.5.4 Troubleshooting for software upgrades

If an error occurred during the upgrade process:

- ▶ Follow the instructions of the error message which is displayed on the PC or on the indicating device.

In case the device still shows the "Remote communication information" dialog:

- ▶ Ensure that the device keypad is not locked.
- ▶ In that case shutdown the device by pressing the ON / OFF key longer than 10 seconds.



NOTE

In most cases, the errors are timeout issues. So if the device shuts down automatically after an operating system upgrade, or restarts the new application after an application upgrade, the upgrade was successful even if the PC displays an error.

To check the new software version:

- ▶ Select menu item "Help".
- ▶ Select submenu item "About EQUOTIP3...".
- ↪ Information about the indicating device is displayed (see p. 44).

5.6 EQUOLINK3 help

The application EQUOLINK3 provides a comprehensive help file system:

- ▶ Select "Help" from the menu bar.
- ▶ Select "Help EQUOLINK3" or "Help PqUpgrade"

or:

- ▶ Select  from the tool bar.

6 Operation



CAUTION

Insufficient preparation of the test procedure

Damage to the unit and / or the sample to be measured.

Before each test procedure:

- ▶ Clean if necessary (see p. 120).
- ▶ Carry out performance check (see p. 115).
- ▶ Check or change settings (scales, statistics activated etc.) (see p. 23).

6.1 Preparation of the sample

Weight and thickness of the test piece

Place specimens under 5 kg (11 lbs) on a solid base so that they cannot be moved or oscillate as a result of the impact.

- ▶ Firmly couple specimens that weigh between 0.1 - 2 kg (0.2 - 4.4 lbs) to an immovable base, e.g. a heavy base plate.

Despite the low mass of the impact body and low impact energy, a relatively large impact force of short duration is generated when the impact body hits the measuring surface.

Impact device types	Classification of samples			Max. impact force
	heavy	medium-weight	light-weight	
D/DC, DL, E	more than 5.0 kg	2.0 - 5.0 kg	0.05 - 2.0 kg	900 N ≈ 90 kgf
G	more than 15.0 kg	5.0 - 15.0 kg	0.50 - 5.0 kg	2,500 N ≈ 250 kgf
C	more than 1.5 kg	0.5 - 1.5 kg	0.02 - 0.5 kg	500 N ≈ 50 kgf

For heavy samples of a compact shape, no particular precautions are necessary. Smaller and lighter samples or workpieces yield or flex under this force, producing L-values which are too small and of excessively large variation. Even with big or heavy workpieces, it is possible for thin wall regions or thinner protruding parts to yield upon impact. Depending on the frequency of the resulting yielding action, the measured L-value may be too small or too large.

In many situations, potential problems can be checked in the following manner:

- ▶ Medium-weight samples and also heavier samples with protruding parts or thin walls should be placed on a solid support in such a manner that they do not move or flex during the test impact.
- ▶ Light-weight samples should be coupled with a non-yielding support such as a heavy base plate to guarantee that they are rigid. Clamping in a vice is of no value, since the samples become exposed to stress and because complete rigidity is never attained, resulting in measured L-values which would be too high and show excessive variations.



NOTE

Incorrect measured values

Thin areas or parts can oscillate slightly upon impact, even in the case of heavy or medium-weight workpieces. This can lead to incorrect values and a clanking noise when an impact is carried out.

Coupling

The following requirements must be met for the coupling:

- The contact surface of the sample and the surface of the base plate must be level, flat and ground smooth.
- The impact must be carried out perpendicular to the coupled surface.

Impact devices types	Minimum sample thickness for coupling
D, DC, DL, E	3 mm / 1/8 in
G	10 mm / 1/2.5 in
C	1 mm / 1/25 in

Coupling procedure



Fig. 6.01 Application of coupling paste

- ▶ Apply a thin layer of coupling paste to the contact surface of the specimen.



Fig. 6.02 Rubbing both parts

- ▶ Press the specimen firmly against the base plate and spread the paste using circular motions.

↪ The coupling process has been carried out properly if there is no longer any metallic contact between the parts.

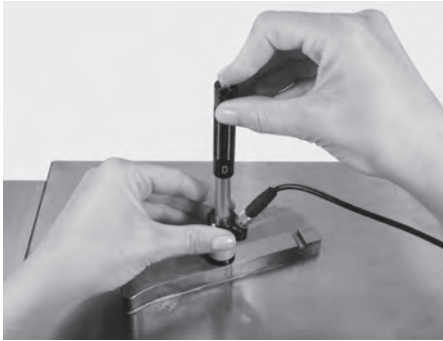

- ▶ Carry out the impact vertically on the specimen (see p. 108).
- ↔ The coupling ensures a rigid connection between the two parts, the absence of surface stress on the specimen and thus reliable test values.

Fig. 6.03 Coupled specimen

Insufficiently coupled samples produce large variations of individual measurements, L-values which are too high and the operation is characterized by a rattling noise upon impact of the test tip.

Surface curvature of the test piece



CAUTION

Radius of curvature of the test piece

Incorrect measured values.

- ▶ Make sure that the radius of curvature of the sample surfaces is not less than 30 mm (1.2 inches).

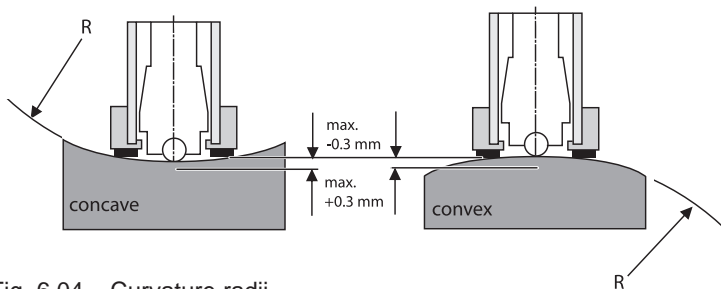

Fig. 6.04 Curvature radii

The unit can only work properly when the impact body is in a particular position in the guide tube at the time of impact on the test surface. In the standard position, the tip of the impact body is precisely at the end of the tube. When concave or convex surfaces are tested, the impact body either does not entirely leave the test tube or comes out too far.

Impact device types	Radius
Impact device type G	$R_{min} = 50 \text{ mm} / 2.0 \text{ in}$
Impact device types D/DC, C and E	$R_{min} = 30 \text{ mm} / 1.2 \text{ in}$

(special support rings are available to accommodate smaller radii on convex or concave surface, see p. 130)

6.2 Triggering the impact



CAUTION

Incorrect triggering of the impact

Incorrect measured values.

When the impact is incorrectly triggered (e.g. the impact device is not correctly positioned), the measured values can be incorrect.

- ▶ Arm the unit and trigger the impact in two separate motions.
- ▶ Do not carry out an impact in an area that has already been deformed by another impact.

Measuring procedure



CAUTION

Arming the impact device

Damage to the impact device.

After depressing the loading tube as far as the bottom end stop (see Fig. 6.05 "Arming"), let it return **slowly** (upward movement) to its initial position, without letting go of the tube. Do not let the loading tube rebound. This applies for all EQUOTIP® impact devices except impact device "DC".



Fig. 6.05 Arming

- ▶ Depress loading tube carefully until contact is felt.
- ▶ Allow it to slowly return to the starting position.
- ↪ The device is now ready for carrying out the hardness test.



Fig. 6.06 Positioning

- ▶ Hold the impact device near the support ring and place it firmly on the test surface.

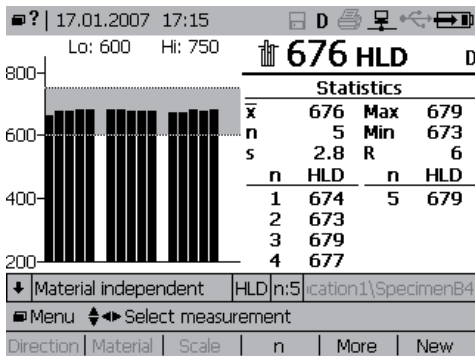

Fig. 6.07 Testing

- ▶ Trigger the impact by exerting light pressure on the release button (take care to not compress the spring).
- ↪ The impact body is released by the catch chuck and launched onto the test surface with a defined energy. The result is immediately shown in the selected hardness scale on the display.
- ↪ If the indicating device has previously been in standby mode (empty display), it will be ready for operation again due to the measuring process (a measured value is not displayed).

▶ Repeat the procedure for a further impact.

↪ After closing the measurement series, the statistics are automatically calculated and the result is displayed:



- ↪ If a measurement failed, there is a visual signal (and depending on the sound settings an acoustic one):

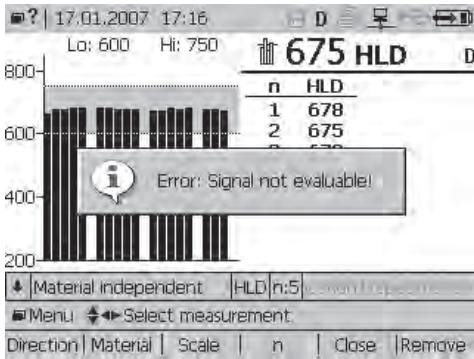

Reactivation in sleep mode

The indicating device goes into idle mode after a set period of time (see p. 20).

To reactivate the indicating device:

- ▶ Load the impact device, trigger the impact or press any key.
- ↪ Previous values are displayed.

i NOTE

Handling of impact device DC

- ▶ Place the loading stick adjacent to the test area.
- ▶ Plunge the face of impact device (coil side) over the stick and press down until it reaches the stop position.
- ↪ The device is now ready for operation.





6.3 Conversion deviations

Measurements with a set conversion produce a scattering. The conversion deviation is the variance resulting from the comparison of measuring values observed with different hardness testing methods. It includes 2 components. The major share is caused by the fact that there is no clear physical relationship between the various methods. The second component results from the circumstance that the comparison of hardness values (e.g. L-value and Brinell) also includes the measuring deviation of the method being compared to. Therefore, a conversion between hardness values contains inaccuracies from the outset.

This applies not only to conversion of the L-value into static indentation hardness values, but also for converting from one static hardness measuring method to another. The conversion deviations (\pm HB, \pm HV, etc.) represent "standard deviations", i.e. 68% of all materials tested to date fell within the specified variance range.

Comparing hardness values with each other is thus always subject to inaccuracies. This not only holds true for the conversion of the L-value to static hardness values but also for the conversion of one static hardness value to another.

If the measurement series is not yet closed, a conversion scale can be selected at any time: before, during or after the measuring process (press "More" to reopen it).

- ▶ Press the  key.
- ▶ Select material.
- ▶ Confirm selection with .
- ▶ Press the  key.
- ▶ Select hardness scale.
- ▶ Confirm selection with .
- ↪ The new conversion is set.



NOTE

Automatic data storage

Irrespective of the measurement settings, all data are automatically stored as original L-values with impact direction and date / time. When converting the values into other scales no additional conversion errors will be introduced.

Setting new conversion after statistics are calculated

- ▶ Press the  key.
- ▶ Follow same procedure as described before.
- ↳ After confirming the new material and hardness scale selection, the display shows the warning message "Your material / scale selection will affect all measurements in this series!". Hardness values which lie outside a conversion are labeled with "noCnv".

Number of impacts per measuring area

- ▶ Test each measuring area by at least 3 to 5 impacts.
- ▶ Do not impact the same point more than once.
- ↳ Mean value "L", standard deviation "s" and range "R" are displayed.
If the range within the same measuring area exceeds $R \geq 30 L$:
- ▶ Check whether the surface of the sample has been adequately ground or whether the sample yields or flexes during the test impact.

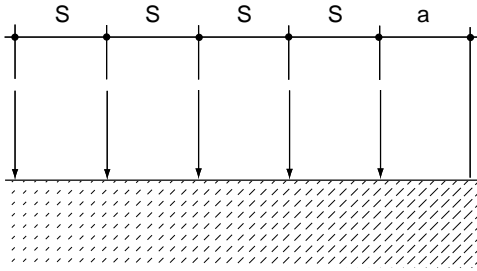

Fig. 6.08 Impact points

Minimum spaces between impact points

Impact device types	s		a	
	mm	in	mm	in
D/DC, DL, E	3	1/8	5	1/5
G	4	1/6	8	1/3
C	2	1/12	4	1/6

6.4 Calculating the mean of hardness values

The EQUOTIP® 3 can be used to calculate statistics. All data are stored in the unit and can be transferred to a PC via USB cable or Ethernet. The mean value of up to 9999 measurements can be determined with the available hardness scales.



NOTE

The measurement series is automatically completed when the currently set number of measurements per series (n) is reached. The following measurement is then the first value of the new measurement series. The series can also be closed manually by pressing the "Close" button (with the  key).

7 Maintenance, storage and care

7.1 Performance check (before each use)

The performance check verifies the mechanical and electronic functions of the impact device and the indicating device. It is accomplished by measuring the hardness value L of the test block applicable to the particular type of impact device (see p. 119).

7.1.1 Indicating device

- ▶ Check the operability of the display (see p. 19).
- ▶ Check the capacity of the battery (see p. 21).

7.1.2 Mechanical and electronic checks

The performance check of the unit should be carried out as follows:

- In the case of continuous operation, at least once a day or at least after every 1,000 impacts
- In the case of infrequent operation, before the beginning and at the end of a test series

The performance check is done by measuring the hardness value L on the test block.

- ▶ Clean the impact device (see p. 120).
- ▶ Carry out impacts on a test block at an interval of 3-5 mm (approx. 3-5 impacts).
- ▶ Read the mean L and compare it with the hardness value as marked on the test block.

The impact device is working properly when the mean value is within the tolerances of ± 6 L and the range R does not exceed 16 L. If it deviates from the mentioned tolerances:

Mean value too high:

- ▶ Change the impact body.

If automatic direction compensation is used:

- ▶ Select for impact direction [vertical down].
- ▶ Repeat the test.
- ▶ Check the wear and mounting of the support ring and replace it if necessary.
- ▶ Clean the impact device and repeat the test.

Mean value too low:

- ▶ Change the impact device and repeat the test.

If the impact device still shows excessive deviations:

- ▶ Do not use the impact device anymore and send it in to the manufacturer to be checked.

With smaller deviations, the L-value can be corrected until the next service according to the following formula:

$$L_k = L * \frac{L_{ref}}{L_{actual}}$$

Example: $L_k = 582 * \frac{764}{774} = 574$ L

L_k	= corrected mean value	574 L
L	= read-OFF mean value during testing a sample	582 L
L_{ref}	= reference value from standard test block	764 L
L_{actual}	= actual value when carrying out measurement operation at the test block	774 L

7.2 Maintenance



CAUTION

Incorrectly performed maintenance

Cancellation of the warranty and liability claims.

- ▶ Always send faulty equipment to an authorized Proceq service center.
- ▶ Periodically ensure correct functioning on a calibrated test block.
- ▶ Have the unit calibrated by an authorized Proceq service center once a year.



NOTE

Maintenance by specialist dealer

International quality standards recommend an annual general check and recalibration of the EQUOTIP® 3 by a specialist dealer.

Every repair carried out by Proceq takes place according to the ISO 9001 quality system and includes the following services:

- Receiving inspection
- Troubleshooting and diagnostics
- Cost estimate, if desired
- Complete cleaning
- Repair to specifications
- Calibration and adjustment
- Outgoing inspection

Maintenance of the impact body

To ensure that the impact body is in good condition, it should be tested regularly on a test block (performance check, see p. 115). The impact body is subject to wear and can be easily and economically replaced by the user (calibration of the impact device is required, see p. 49).

The impact body is assembled in a special manner with critical precision and cannot be repaired.

7.2.1 Changing the battery



CAUTION

Changing the battery

Reset of the lifetime indicator even if the battery is fully charged.

- ▶ Do not remove or insert the Lithium-Ion battery while the device is running with an external power supply.

The lifetime indicator can be recalibrated (see below).

The battery compartment is at the bottom on the right side of the indicating device (see p. 9).

- ▶ Push in on the cover of the battery compartment and turn it counter-clockwise at the same time.

↳ The compartment is open and the battery can be replaced.

The battery can be replaced with another Proceq-supplied Lithium-Ion battery, or 3 standard size "C" cells (Alkaline, NiCd or NiMH).



NOTE

Internal battery charge

Only the Proceq-supplied Lithium-Ion battery can be charged internally in the EQUOTIP® 3 indicating device.

- ▶ Close the compartment with the cover.
- ▶ Align the studs with the slots.
- ▶ Push down the cover and turn it clockwise at the same time until it reaches its initial position.



The supplied Lithium-Ion battery can be recycled.

Recalibration of lifetime indicator

- ▶ Discharge the battery completely (have the device running at full battery power until it switches OFF automatically).
- ▶ Recharge the battery completely while the device is running.
- ▶ To verify the battery state, go to menu item "Show system info..." and see the "Battery charged and discharged" time stamps and the battery life percentage remaining.



DANGER

Wrong handling of Lithium-Ion batteries

Injuries / Pollution

- ▶ Do not crush.
- ▶ Do not heat or incinerate.
- ▶ Do not short circuit.
- ▶ Do not dismantle.
- ▶ Do not immerse in any liquid as it may vent or rupture.
- ▶ Observe charging instructions.
- ▶ Do not charge below 0°C or above 45°C.
- ▶ Discharge only in a temperature range of -20°C to 50°C.

7.2.2 EQUOTIP® test blocks with Proceq calibration

EQUOTIP® test blocks are calibrated with standard devices according to the EQUOTIP® calibration basis by Proceq SA and bear a calibration certificate.

The EQUOTIP® calibration basis corresponds to the standard of the Quality Management System ISO 9001:1994 / chapt. 11 and is regularly inspected. The strict observance of the values marked on the test block guarantees the correct functioning of the impact device and the indicating device throughout the entire measuring range.



NOTE

EQUOTIP® test blocks

The EQUOTIP® test blocks are labeled with the type, unique serial number and reference values (see p. 129).



NOTE

Grinding standard test blocks

Densely impacted standard test blocks cannot be restored by grinding. Through grinding, the original hardness is altered in an uneven and uncontrolled manner. Therefore the standard test blocks can neither be calibrated for a new mean value nor for an acceptable \pm tolerance.

7.3 Storage

- ▶ Only store EQUOTIP® 3 in the original packaging and in a dry room that is as free from dust as possible.

7.4 Cleaning (after each use)



CAUTION

Liquids and caustic substances

Damage to the unit.

- ▶ Never immerse the unit in water or clean it under running water.
- ▶ Do not use abrasives, solvents or lubricants to clean the unit.

The devices do not require any particular care other than periodic cleaning of the impact body and the guide tube after performing approximately 1,000 - 2,000 tests.



NOTE

Proceq website

Important information on the maintenance and care of your unit can also be found at www.proceq.com.

7.4.1 Guide tube

- ▶ Unscrew the support ring.
- ▶ Remove the impact body from the guide tube.
- ▶ Clean all dirt and metallic powder from the impact body.
- ▶ Clean the guide tube with the cleaning brush (accessory).
- ▶ If necessary, clean the gaps with a pneumatic pump (no compressed air!).
- ▶ Do not apply oil, grease or other lubricants to any parts for the impact device.

After cleaning:

- ▶ Test the calibration of the impact device (see p. 49) and recalibrate it if necessary.

7.4.2 Indicating device

- ▶ Clean the display with a clean, dry cloth after each use.
- ▶ Clean any dirty input socket with a clean, dry brush.

8 Troubleshooting

Problem description	Problem solution
No display	<p>Indicating device is in standby state.</p> <ul style="list-style-type: none">▶ Press any key, load the impact device or:▶ Perform a measurement. <p>Discharged battery.</p> <ul style="list-style-type: none">▶ Charge battery (see p. 21). <p>Indicating device is too cold.</p> <ul style="list-style-type: none">▶ Go to a room with higher temperatures. <p>Poor cable contact or cable broken.</p> <ul style="list-style-type: none">▶ Insert cable fully or replace cable. <p>Device has crashed or did not completely shut down.</p> <ul style="list-style-type: none">▶ Press and hold the ON / OFF key for at least 10 seconds.▶ Press the ON / OFF key again to switch ON the indicating device.
No impact	<p>Impact body is not inserted or incorrectly inserted in the impact unit.</p> <ul style="list-style-type: none">▶ Insert the impact body correctly. <p>Impact body is not released or cannot be armed.</p> <ul style="list-style-type: none">▶ Use new impact body.▶ Have the impact device checked or replace the impact device.
Measured values are incorrect.	<p>Impact was carried out incorrectly.</p> <ul style="list-style-type: none">▶ Carry out the arming motion and trigger the impact in two separate motions (see p. 108).



Problem description	Problem solution
Individual values are scattered very widely or are continuously too low.	<p>The testing point is insufficiently prepared.</p> <ul style="list-style-type: none"> ▶ Carefully prepare the testing point and sample for the impact (see p. 104). <p>Sample is insufficiently supported.</p>
L-values on test block are continuously too low.	<p>Impact device is dirty.</p> <p>Impact body is damaged.</p> <ul style="list-style-type: none"> ▶ Replace impact body.
L-values on test block are continuously too high.	<p>Impact body tip flattened.</p> <ul style="list-style-type: none"> ▶ Replace impact body. <p>Test block is worn.</p> <ul style="list-style-type: none"> ▶ Replace test block.
The LED does not go OFF, even though the battery has been charged for several days (section 3.4, see p. 21).	<p>The battery life has expired.</p> <ul style="list-style-type: none"> ▶ Replace the battery (see p. 118).
Incorrect measurement settings were made.	<ul style="list-style-type: none"> ▶ Carry out impact. ▶ Repeat settings.
Indicating device cannot be switched OFF: there is no reaction.	<p>The EQUOTIP® operating system software has crashed.</p> <ul style="list-style-type: none"> ▶ Press and hold the ON / OFF key for at least 10 seconds. ▶ Press the ON / OFF key again to switch ON the indicating device.

Problem description	Problem solution
<p>Application reacts very slowly. (Examples: Keys must be pressed for several seconds until the key press is registered or measurements are displayed with a delay of several seconds.)</p>	<p>A system thread ("Compaction Thread") cleans up the flash disk when there are too many invalid sectors. It is a common and necessary task.</p> <ul style="list-style-type: none"> ▶ Wait some minutes or ▶ Continue work under this special condition. <p>The more you write to flash (measurement series, device power up, device upgrade & shutdown cycles), the more frequently this condition occurs.</p>

9 Parts & accessories

9.1 Ordering information

9.1.1 Units

Unit	Description	Part no.
	<p>Includes EQUOTIP® 3 indicating device, EQUOTIP® impact device D, test block D, carrying case, USB cable, USB memory stick, cleaning brush, power supply unit, coupling paste, support ring D6 and D6a, operating instructions, quick reference guide and calibration certificate.</p>	353 10 100
	<p>Includes EQUOTIP® 3 indicating device, EQUOTIP® impact device G, test block G, carrying case, USB cable, USB memory stick, cleaning brush, power supply unit, operating instructions, quick reference guide and calibration certificate.</p>	353 10 300
	<p>Includes EQUOTIP® 3 indicating device, carrying case, USB cable, USB memory stick, power supply unit, operating instructions and quick reference guide.</p> <p>The customer needs to buy additionally with the EQUOTIP® basic unit the appropriate impact device and test block (see next page).</p>	353 10 050
<p>The EQUOTIP® 3 (Part no. 353 10 050) basic unit gives the customer the opportunity to create his own EQUOTIP® hardness tester unit for his specific measuring requirements.</p>		

9.1.2 Accessories

Part no.	Description
353 00 083	Impact device cable existing EQ2 impact device to new EQ3 indicating device
353 00 084	Impact device cable new EQ3 impact device to existing EQ2 indicating device
353 00 080	EQ3 impact device cable, 1.5 m 4-pole
353 00 086	EQ3 impact device extension cable, 5 m 4-pole
351 90 018	USB cable, 1.8 m
353 00 082	EQUOTIP® 3 RS232 adapter cable for connection to printer
353 00 029	Rechargeable EQ3 battery
353 00 085	Power supply unit (AC adapter)
353 99 011	EQUOTIP® 3 carrying case with cut-out for test block (except G) and accessories
353 00 037	EQUOTIP® 3 neck / wrist strap
350 01 009	Support ring D6*
350 01 010	Support ring D6a*
350 01 008	Cleaning brush D
350 08 004	Support ring G6*
350 08 005	Support ring G6a*
350 08 006	Cleaning brush G
350 01 015	Coupling paste (Can)
350 01 007	Loading stick impact device DC
* Wear parts	

9.2 Impact devices

Impact device D (assembly) Part no. 353 00 100	Description (available as individual part)	Part no.
	EQUOTIP® 3 basic impact device D w/o impact body, support rings, cleaning brush, cable (4-pole)	353 00 101
	EQUOTIP® impact body D/DC	350 01 004
	Support ring D6	350 01 009
	Support ring D6a	350 01 010
	Cleaning brush D	350 01 008
	1.5 m 4-pole connector cable between EQ3 indicating device and impact device	353 00 080

Impact device G (assembly) Part no. 353 00 300 	Description (available as individual part)	Part no.
	EQUOTIP® 3 basic impact device G w/o impact body, support rings, cleaning brush, cable (4-pole)	353 00 301
	EQUOTIP® impact body G	350 08 002
	Support ring G6	350 08 004
	Support ring G6a	350 08 005
	Cleaning brush G	350 08 006
	1.5 m 4-pole connector cable between EQ3 indicating device and impact device	353 00 080

Impact device DC (assembly) Part no. 353 00 110 	Description (available as individual part)	Part no.
	EQUOTIP® 3 basic impact device DC w/o impact body, support rings, cleaning brush, cable (4-pole)	353 00 111
	EQUOTIP® impact body D/DC	350 01 004
	Support ring D6	350 01 009
	Support ring D6a	350 01 010
	Loading stick	350 01 007
	Cleaning brush D	350 01 008
1.5 m 4-pole connector cable between EQ3 indicating device and impact device	353 00 080	

Impact device DL (assembly) Part no. 353 00 120 	Description (available as individual part)	Part no.
	EQUOTIP® 3 basic impact device DL w/o impact body, support rings, cleaning brush, cable (4-pole)	353 00 121
	EQUOTIP® impact body DL	350 71 311
	Support ring DL	350 71 314
	Plexiglass sleeve	350 71 316
	Cleaning brush D	350 01 008
	1.5 m 4-pole connector cable between EQ3 indicating device and impact device	353 00 080

Impact device E (assembly) Part no. 353 00 400 	Description (available as individual part)	Part no.
	EQUOTIP® 3 basic impact device E w/o impact body, support rings, cleaning brush, cable (4-pole)	353 00 401
	EQUOTIP® impact body E	350 07 002
	Support ring D6	350 01 009
	Support ring D6a	350 01 010
	Cleaning brush D	350 01 008
	1.5 m 4-pole connector cable between EQ3 indicating device and impact device	353 00 080

Impact device C (assembly) Part no. 353 00 500 	Description (available as individual part)	Part no.
	EQUOTIP® 3 basic impact device C w/o impact body, support rings, cleaning brush, cable (4-pole)	353 00 501
	EQUOTIP® impact body C	350 05 003
	Support ring D6	350 01 009
	Support ring D6a	350 01 010
	Cleaning brush D	350 01 008
1.5 m 4-pole connector cable between EQ3 indicating device and impact device	353 00 080	

Impact device S (assembly) Part no. 353 00 200 	Description (available as individual part)	Part no.
	EQUOTIP® 3 basic impact device S w/o impact body, support rings, cleaning brush, cable (4-pole)	353 00 201
	EQUOTIP® impact body S	350 71 413
	Support ring D6	350 01 009
	Support ring D6a	350 01 010
	Cleaning brush D	350 01 008
1.5 m 4-pole connector cable between EQ3 indicating device and impact device	353 00 080	

9.3 Test blocks

9.3.1 EQUOTIP® test blocks with Proceq calibration certificate

Test block	Impact device calibrated with	Also suitable for use with	Other scales marked on test block
D Proceq calibrated approx. 765 LD / 55 HRC Part no. 350 01 140	D DC	DL C E S	HRC
G Proceq calibrated approx. 572 LG / 340 HB Part no. 350 08 008	G	D	HBW 5/750

9.3.2 EQUOTIP® test blocks with MPA certificate

Test Blocks D/MPA, G/MPA, E/MPA and S/MPA are calibrated in accordance with the dynamic hardness value L by Proceq SA and to the static hardness value of Rockwell (HRC) or Brinell (HB) by an independent traceable test laboratory. These test blocks are supplied with 2 separate certificates - a certificate to the EQUOTIP® L-value (Proceq SA) and a certificate to Brinell or Rockwell (MPA). Type, identification, reference values etc. are engraved on the test blocks see examples below.

Test block	Impact device calibrated with	Also suitable for use with	Other scales marked on test block
D MPA calibrated approx. 765 LD / 55 HRC Part no. 350 01 139	D DC	DL C E S	HRC
G MPA calibrated approx. 572 LG / 340 HB Part no. 350 08 009	G	D	HBW 5/750

Test block	Impact device calibrated with	Also suitable for use with	Other scales marked on test block
E Only available as MPA calibrated approx. 813 LE / 64 HRC Part no. 350 01 135	E	not applicable	HRC
S Only available as MPA calibrated approx. 876 LS / 64 HRC Part no. 350 01 125	S	not applicable	HRC

9.4 Support rings

9.4.1 Standard support rings

Picture	Description	Part no.
	Support ring D6	350 01 009
	Support ring D6a	350 01 010
	Support ring G6	350 08 004
	Support ring G6a	350 08 005
	Support ring DL	350 71 314

9.4.2 Optional support rings for curved or special geometries

Picture	Description	Part no.
	Set of support rings (12 pcs.)	350 03 000
	Support ring Z 10-15	350 03 001
	Support ring Z 14.5-30	350 03 002
	Support ring Z 25-50	350 03 003
	Support ring HZ 11-13	350 03 004
	Support ring HZ 12.5-17	350 03 005
	Support ring HZ 16.5-30	350 03 006
	Support ring K 10-15	350 03 007
	Support ring K 14.5-30	350 03 008

Picture	Description	Part no.
	Support ring HK 11-13	350 03 009
	Support ring HK 12.5-17	350 03 010
	Support ring HK 16.5-30	350 03 011
	Support ring UN	350 03 012

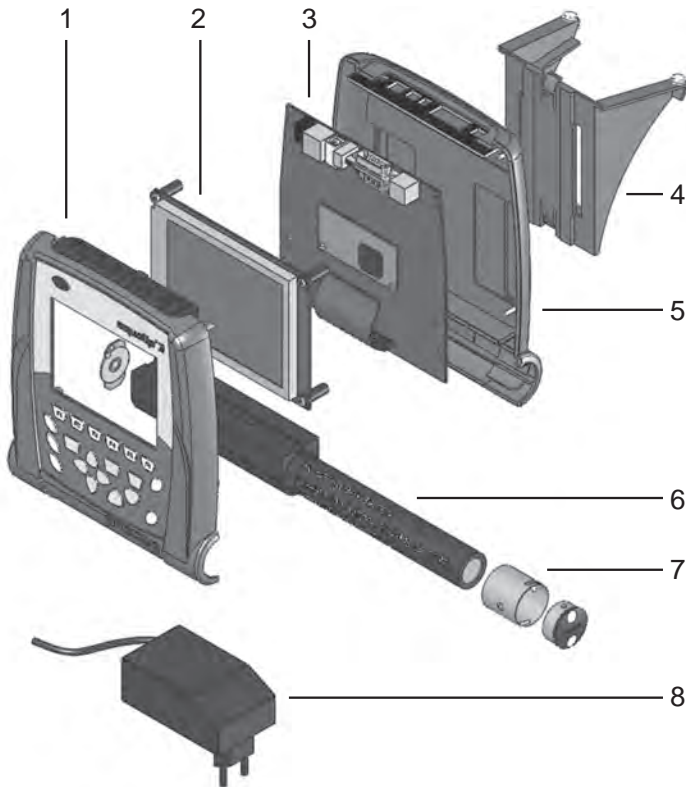



Fig. 9.01 Explosion drawing EQUOTIP® 3 indicating device

Pos. no.	Description	Part no.
1	Upper part housing assembly	353 00 036
2	LCD display assembly	353 00 031
3	PCBs board	353 00 030
4	Stand assembly	353 00 010
5	Lower part housing	353 00 025
6	Rechargeable EQ3 battery	353 00 029
7	Battery assembly	353 00 034
8	Power supply unit (AC adapter)	353 00 085

9.5 Technical data

Indicating device

Dimensions	170 x 200 x 45 mm (6.7 x 7.9 x 1.8 in)
Weight	780 g plus approx. 120 g battery pack
Unit material	Shock resistant ABS plastics
Unit display	QVGA LCD with LED backlight, 4.7 in
Resolution	1 HL; 1 HV; 1 HB; 0.1 HRC; 0.1 HRB; 0.1 HS; 1 MPa (N/mm ²)
Internal data storage	Over 100,000 measured values
Battery type	PQ-EQ3 Part no. 35300029 Rechargeable Lithium-Ion 1S2P CGR 18650
	 Recyclable
Battery nominal voltage	3.7 V
Battery maximum charge voltage	4.2 V
Battery nominal capacity	4.3 Ah
Battery operation period with fully charged battery	Typical 10 hours
Input voltage	9 - 16 V DC
Max. input current @ 12 V input voltage	1 A
Max. input current @ 9.4 V input voltage	1.3 A
Operating temperature	0 to +50°C (32 to 122°F)
Storage temperature	-10 to +60°C (14 to 140°F)
Humidity	Non-condensing, 90% max.
Interfaces	RS232, Ethernet, USB 1.1
Input socket impact device	20-pole
Electromagnetic compatibility (EMC)	DIN EN 61000-6-2; 61000-6-3 61000-4-2 up to 61000-4-6 61000-4-11; DIN EN 55022



PRODUCT REGISTRATION

Warranty Card

Product

Instrument type: **EQUOTIP 3**

Instrument no.:

Purchasing date:

Purchased from (Proceq Agent):

Location:

Customer Info

Name:

Address:

Location:

Phone:

E-mail:

Fax it to Proceq:

Proceq Europe: Fax +41-(0)43-355-38-12

Proceq USA, Inc.: Fax +1-724-512-0331

Proceq Asia Pte Ltd: Fax +65-6382-3307

Online Registration:

Link to Online Registration: www.proceq.com/

- Select your area (North/South America, Europe/Africa, Asia/Pacific)
- Use the Link "Register"



proceq